



# Kraftfahrt-Bundesamt

DE-24932 Flensburg

---



## MITTEILUNG

ausgestellt von:

**Kraftfahrt-Bundesamt**

**über die Genehmigung**

**für einen Typ eines Fahrtrichtungsanzeigers nach der Regelung Nr. 6  
einschließlich der Änderung 01 Ergänzung 25**

## COMMUNICATION

issued by:

**Kraftfahrt-Bundesamt**

**concerning approval granted**

**of a type of direction indicator pursuant to Regulation No. 6  
including amendment 01 supplement 25**

Nummer der Genehmigung: **013922**  
Approval No.:

Erweiterung Nr.: --  
Extension No.:

1. Fabrik- oder Handelsmarke der Einrichtung:  
Trade name or mark of the device:  
**JUNYAN**
2. Bezeichnung des Typs der Einrichtung durch den Hersteller:  
Manufacturer's name for the type of device:  
**HU303-00-1**
3. Name und Anschrift des Herstellers:  
Manufacturer's name and address:  
**JUN YAN AUTO INDUSTRIAL CO., LTD.**  
**TW-Tainan City 704**
4. Gegebenenfalls Name und Anschrift des Vertreters des Herstellers:  
If applicable, name and address of the manufacturer's representative:  
**Integrated Services of Quality Assessment**  
**TW-41257 Da-Li, Taichung**



# Kraftfahrt-Bundesamt

DE-24932 Flensburg

---

2

Nummer der Genehmigung: 013922

Approval No.:

5. Zur Genehmigung vorgelegt am:

Submitted for approval on:

**09.02.2015**

6. Technischer Dienst, der die Prüfungen für die Genehmigung durchführt:

Technical service responsible for conducting approval tests:

**ISOQA Technischer Dienst GmbH**

**DE-76137 Karlsruhe**

7. Datum des Gutachtens:

Date of test report issued by that service:

**02.02.2015**

8. Nummer des Gutachtens:

Number of test report issued by that service:

**ISOQA-14-0132-R6**

9. Kurze Beschreibung:

Concise description:

Kategorie: **1**

Category:

Signal für die Ausfallanzeige vorhanden: **nicht erforderlich**

Signal for activation of the tell-tale available: **not necessary**

Anzahl, Kategorie und Art der Lichtquelle(n): **1 x PY21W**

Number, category and kind of light source(s):

Von einer zu einem System voneinander abhängiger Leuchten gehörende Leuchten  
wahrgenommene Funktion(en): **nein**

Function(s) produced by an interdependent lamp forming part of an interdependent  
lamps system: **no**

Spannung und Leistung: **12V 21W**

Voltage and wattage:

Spezifischer Identifizierungskode des Lichtquellenmoduls: **entfällt**

Light source module specific identification code: **not applicable**

Nur für eine begrenzte Anbauhöhe von höchstens 750 mm über dem Boden: **nein**

Only for limited mounting height of equal to or less than 750 mm above the ground: **no**



# Kraftfahrt-Bundesamt

DE-24932 Flensburg

---

3

Nummer der Genehmigung: 013922

Approval No.:

Geometrische Bedingungen für die Anbringung und mögliche Abweichungen, sofern zutreffend:

Geometrical conditions of installation and relating variations, if any:

**Bezugsachse parallel zur Fahrzeuginnerebene und parallel zur Standfläche des Fahrzeugs auf der Fahrbahn (siehe anliegende Zeichnung)**  
**reference axis parallel to the median longitudinal plane of the vehicle and parallel to the bearing plane of the vehicle on the road (see attached drawing)**

Anwendung eines elektronischen Lichtquellen-Vorschaltgerätes/einer variablen Helligkeitssteuerung:

Application of an electronic light source control gear/variable intensity control:

- (a) als Teil der Lampe: **nein**  
being part of the lamp: **no**
- (b) nicht als Teil der Lampe: **nein**  
being not part of the lamp: **no**

Durch elektronisches Lichtquellen-Vorschaltgerät/variable Helligkeitssteuerung zugeführte Eingangsspannung:

Input voltage(s) supplied by an electronic light source control gear/variable intensity control:

**entfällt**  
**not applicable**

Hersteller und Identifizierungsnummer des elektronischen Lichtquellen-Vorschaltgerätes /der variablen Helligkeitssteuerung (falls das elektronische Lichtquellen-Vorschaltgerät Teil der Lampe ist und nicht im Lampengehäuse enthalten ist):

Electronic light source control gear/variable intensity control manufacturer and identification number (when the light source control gear is part of the lamp but is not included into the lamp body):

**entfällt**  
**not applicable**

Variable Beleuchtungsstärke: **nein**

Variable luminous intensity: **no**

Aufeinander folgende Aktivierung von Lichtquellen (siehe Absatz 5.6): **nein**

Sequential activation of light sources (see paragraph 5.6 of this Regulation): **no**

10. Anbringungsstelle des Genehmigungszeichens:

Position of the approval mark:

**auf der Abschlusscheibe**  
**on the lens**



# Kraftfahrt-Bundesamt

DE-24932 Flensburg

4

Nummer der Genehmigung: 013922

Approval No.:

11. Grund (Gründe) für die Erweiterung der Genehmigung (falls zutreffend):  
Reason(s) for extension (if applicable):  
**entfällt**  
**not applicable**
12. Genehmigung **erteilt**  
Approval **granted**
13. Ort: **DE-24932 Flensburg**  
Place:
14. Datum: **26.02.2015**  
Date:
15. Unterschrift: **Im Auftrag**  
Signature:

Stephan Marxsen



16. Das Verzeichnis der Unterlagen, die bei der Behörde hinterlegt sind, die die Genehmigung erteilt hat, und auf Anfrage erhältlich sind, ist dieser Benachrichtigung beigelegt.  
The list of documents deposited with the Administrative Service which has granted approval is annexed to this communication and may be obtained on request.

## **Nebenbestimmungen und Rechtsbehelfsbelehrung** **Collateral clauses and instruction on right to appeal**

- 1 **Prüfbericht mit Anlagen**  
**Test report with enclosures**



# Kraftfahrt-Bundesamt

DE-24932 Flensburg

Nummer der Genehmigung: 013922

Approval No.:

**- Anlage -**

## Nebenbestimmungen und Rechtsbehelfsbelehrung

### Nebenbestimmungen

Jede Einrichtung, die dem genehmigten Typ entspricht, ist gemäß der angewendeten Vorschrift zu kennzeichnen.

Das Genehmigungszeichen lautet wie folgt:

**für linksseitigen Einbau**

01 1



3922

**für rechtsseitigen Einbau**

01 1



3922

Die Einzelerzeugnisse der reihenweisen Fertigung müssen mit den Genehmigungsunterlagen genau übereinstimmen. Änderungen an den Einzelerzeugnissen sind nur mit ausdrücklicher Zustimmung des Kraftfahrt-Bundesamtes gestattet.

Änderungen der Firmenbezeichnung, der Anschrift und der Fertigungsstätten sowie eines bei der Erteilung der Genehmigung benannten Zustellungsbevollmächtigten oder bevollmächtigten Vertreters sind dem Kraftfahrt-Bundesamt unverzüglich mitzuteilen.

Verstöße gegen diese Bestimmungen können zum Widerruf der Genehmigung führen und können überdies strafrechtlich verfolgt werden.

Die Genehmigung erlischt, wenn sie zurückgegeben oder entzogen wird, oder der genehmigte Typ den Rechtsvorschriften nicht mehr entspricht. Der Widerruf kann ausgesprochen werden, wenn die für die Erteilung und den Bestand der Genehmigung geforderten Voraussetzungen nicht mehr bestehen, wenn der Genehmigungsinhaber gegen die mit der Genehmigung verbundenen Pflichten – auch soweit sie sich aus den zu dieser Genehmigung zugeordneten besonderen Auflagen ergeben - verstößt oder wenn sich herausstellt, dass der genehmigte Typ den Erfordernissen der Verkehrssicherheit oder des Umweltschutzes nicht entspricht.

Das Kraftfahrt-Bundesamt kann jederzeit die ordnungsgemäße Ausübung der durch diese Genehmigung verliehenen Befugnisse, insbesondere die genehmigungsgerechte Fertigung sowie die Maßnahmen zur Übereinstimmung der Produktion, nachprüfen. Es kann zu diesem Zweck Proben entnehmen oder entnehmen lassen. Dem Kraftfahrt-Bundesamt und/oder seinen Beauftragten ist ungehinderter Zutritt zu Produktions- und Lagerstätten zu gewähren.

Die mit der Erteilung der Genehmigung verliehenen Befugnisse sind nicht übertragbar. Schutzrechte Dritter werden durch diese Genehmigung nicht berührt.



# Kraftfahrt-Bundesamt

DE-24932 Flensburg

---

2

Nummer der Genehmigung: 013922

Approval No.:

## **Rechtsbehelfsbelehrung**

Gegen diese Genehmigung kann innerhalb eines Monats nach Bekanntgabe Widerspruch erhoben werden. Der Widerspruch ist beim **Kraftfahrt-Bundesamt, Fördestraße 16, DE-24944 Flensburg**, schriftlich oder zur Niederschrift einzulegen.



# Kraftfahrt-Bundesamt

DE-24932 Flensburg

---

3

Nummer der Genehmigung: 013922

Approval No.:

**- Attachment -**

## **Collateral clauses and instruction on right to appeal**

### **Collateral clauses**

All equipment which corresponds to the approved type is to be identified according to the applied regulation.

The approval identification is as follows: - see German version -

The individual production of serial fabrication must be in exact accordance with the approval documents. Changes in the individual production are only allowed with express consent of the Kraftfahrt-Bundesamt.

Changes in the name of the company, the address and the manufacturing plant as well as one of the parties given the authority to delivery or authorised representative named when the approval was granted is to be immediately disclosed to the Kraftfahrt-Bundesamt.

Breach of this regulation can lead to recall of the approval and moreover can be legally prosecuted.

The approval expires if it is returned or withdrawn or if the type approved no longer complies with the legal requirements. The revocation can be made if the demanded requirements for issuance and the continuance of the approval no longer exist, if the holder of the approval violates the duties involved in the approval, also to the extent that they result from the assigned conditions to this approval, or if it is determined that the approved type does not comply with the requirements of traffic safety or environmental protection.

The Kraftfahrt-Bundesamt may check the proper exercise of the conferred authority taken from this approval at any time. In particular this means the compliant production as well as the measures for conformity of production. For this purpose samples can be taken or have taken. The employees or the representatives of the Kraftfahrt-Bundesamt may get unhindered access to the production and storage facilities.

The conferred authority contained with issuance of this approval is not transferable. Trade mark rights of third parties are not affected with this approval.

### **Instruction on right to appeal**

This approval can be appealed within one month after notification. The appeal is to be filed in writing or as a transcript at the **Kraftfahrt-Bundesamt, Fördestraße 16, DE-24944 Flensburg.**

**Test Report No. : ISOQA-14-0132-R6**

Approval No. : 6R-01 3922  
Type : HU303-00-1  
Manufacturer : JUN YAN AUTO INDUSTRIAL CO., LTD.



Laboratory to ISOQA Technischer Dienst GmbH  
Web: [www.isoqa.org](http://www.isoqa.org)  
E-mail: [isoqa@isoqa.org](mailto:isoqa@isoqa.org)

## TEST REPORT

Concerning the adoption of uniform technical prescriptions for wheeled vehicles, equipment and parts which can be fitted and/or be used on wheeled vehicles and the conditions for reciprocal recognition of approvals granted on the basis of these prescriptions.

**Uniform provisions concerning the approval of direction indicators for power-driven vehicles and their trailers**

**Tested according ECE-R6, supplement 25 to the 01 series of amendments of 09 October 2014.**

Kind of device: Front Direction Indicator, Category 1

Approval status	
X	Application for granting of a type approval
	Application for an extension of type approval No.
	Reason for the extension:



## Test Report No. : ISOQA-14-0132-R6

Approval No. : 6R-01 3922  
Type : HU303-00-1  
Manufacturer : JUN YAN AUTO INDUSTRIAL CO., LTD.



Laboratory to ISOQA Technischer Dienst GmbH  
Web: [www.isoqa.org](http://www.isoqa.org)  
E-mail: [isoqa@isoqa.org](mailto:isoqa@isoqa.org)

### 0. General

- 0.1. Make (trade name of manufacturer) : JUNYAN
- 0.2. Type : HU303-00-1
- 0.3. Class of the connecting device : Category 1
- 0.4. Manufacturer's name and address : JUN YAN AUTO INDUSTRIAL CO., LTD.  
No.121, Wencheng Road,  
704 Tainan,  
Taiwan, Republic of China
- 0.5. Test laboratory : ISOQA (Laboratory to ISOQA Technischer Dienst GmbH)  
60, Yong Long Road,  
41257 Da-Li, Taichung  
Taiwan

**Test Report No. : ISOQA-14-0132-R6**

Approval No. : 6R-01 3922  
 Type : HU303-00-1  
 Manufacturer : JUN YAN AUTO INDUSTRIAL CO., LTD.



Laboratory to ISOQA Technischer Dienst GmbH  
 Web: [www.isoqa.org](http://www.isoqa.org)  
 E-mail: [isoqa@isoqa.org](mailto:isoqa@isoqa.org)

**1. Test object (s)**

## 1.1. Information :

Material of Lens	Sabic Lexan LS-2 111 with UVHC 3000 Coating	
Material of Housing	Plastic	
Material of Reflector	Plastic	
Rated Voltage	12V	
Front Direction Indicator	Category	1
	Light Source	1 x PY21W, 12V, 21W
	Color of light emitted	Amber
	Color of lens	Clear
	Signal for activation of the tell-tale	N/A
	Visibility	The devices cannot be mounted on either side of the vehicle indiscriminately, the horizontal arrow is required.
	Grouped with	Front Position Lamp, Daytime running lamp, Driving Beam and Passing Beam
	Combined with	--
	Incorporated with	--

1.2. Location of Marking : see Appendix 2

1.3. Remark(s) :

1.3.1 There are no objections against the variants that may be described in the Information folder respectively the information document by the manufacturer because adversely effects are not expected.

The lamps are part of the same assembly of grouped, combined or reciprocally incorporated lamps. Each of these lamps satisfies the requirements of the relevant regulation.

## Test Report No. : ISOQA-14-0132-R6

Approval No. : 6R-01 3922  
Type : HU303-00-1  
Manufacturer : JUN YAN AUTO INDUSTRIAL CO., LTD.



Laboratory to ISOQA Technischer Dienst GmbH  
Web: [www.isoqa.org](http://www.isoqa.org)  
E-mail: [isoqa@isoqa.org](mailto:isoqa@isoqa.org)

## 2. Test Specification

- 2.1. Place of test : Laboratory of ISOQA in Taiwan
- 2.2. Date of test : 2014/9/18 ~ 2014/12/17
- 2.3. Date of receipt of test device(s) : 2014/9/18
- 2.4. Test results :**
- 2.4.1. Markings (according to paragraph 3 of ECE R6-01)
- |   |                |                 |
|---|----------------|-----------------|
| a. trade name or mark                   | Complies       | see Appendix 2  |
| b. Light sources                        | Complies       | see Appendix 2  |
| c. Space reserved for the approval mark | Complies       | see Appendix 2. |
| d. Light source module(s)               | Not Applicable |                 |
- 2.4.2. General Specifications (according to paragraph 5 of ECE R6-01)
- |   |                |  |
|---|----------------|--|
| a. Conformity of specifications                       | Complies       |  |
| b. Design and construction for satisfactory operation | Complies       |  |
| c. Light sources module                               | Not Applicable |  |
| d. replaceable filament lamp(s)                       | Complies       |  |
| e. Variable intensity control                         | Not Applicable |  |
- 2.4.3. Intensity of light emitted (according to paragraph 6 of ECE R6-01)
- |  |                |         |
|--|----------------|---------|
| a. Light distribution                    | Complies       | see 3.1 |
| b. Visibility                            | Complies       | see 3.1 |
| c. failure of more than one light source | Not Applicable |         |
- 2.4.4. colour of light emitted (according to paragraph 8 of ECE R6-01)
- |  |          |         |
|--|----------|---------|
|  | Complies | see 3.2 |
|--|----------|---------|
- 2.5. Remark (s) --



**Test Report No. : ISOQA-14-0132-R6**

Approval No. : 6R-01 3922  
 Type : HU303-00-1  
 Manufacturer : JUN YAN AUTO INDUSTRIAL CO., LTD.

### 3.2. Color of light emitted test record

Type Name	: HU303-00-1	Engineer	: Bo Yang Lee
Function	: Front Direction Indicator	Category	: 1
Flux	: 13.5V: 280 lm	Light Source	: 1 x PY21W
Distance	: 2.904 m	Current	: 1.885 A / 1.885 A

Function (s)	Color of light emitted	Sample 1 (LHM)		Sample 2 (RHM)		Result
		x	y	x	y	
Front Direction Indicator	Amber	0.5857	0.4122	0.5898	0.4084	Pass

### 3.3. Determination of the apparent surface

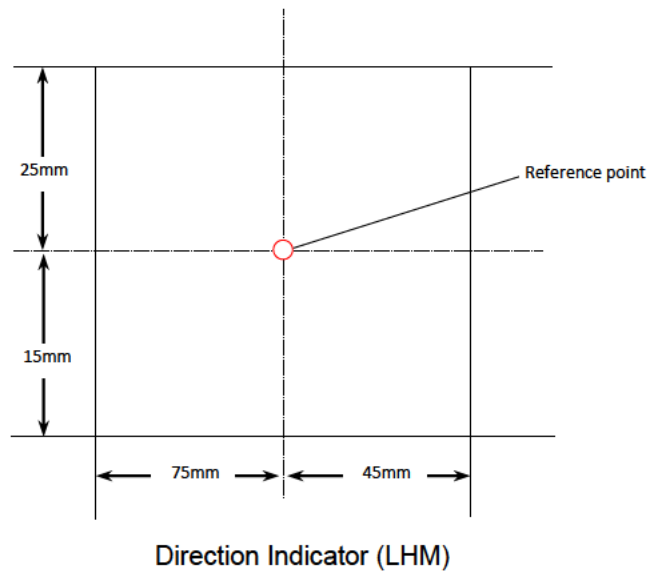

## Test Report No. : ISOQA-14-0132-R6

Approval No. : 6R-01 3922  
Type : HU303-00-1  
Manufacturer : JUN YAN AUTO INDUSTRIAL CO., LTD.



Laboratory to ISOQA Technischer Dienst GmbH  
Web: [www.isoqa.org](http://www.isoqa.org)  
E-mail: [isoqa@isoqa.org](mailto:isoqa@isoqa.org)

### 4. Communication

Concerning : APPROVAL GRANTED

of a type of device pursuant to Regulation No. 6

Approval No. 6R-01 3922 Extension No. 00

#### 4.1. Concise description

4.1.1	By category of lamp	:	1
	Number, category and kind of light source(s)	:	1 X PY21W
	Function(s) produced by an interdependent lamp forming part of an interdependent lamps system	:	N/A
	Voltage and wattage	:	12V 21W
	Light source module specific identification code	:	N/A
	Only for limited mounting height of equal to or less than 750mm above the ground	:	NO
	Geometrical conditions of installation and relating variations, if any	:	Reference axis parallel to the median longitudinal plane of the vehicle and parallel to the bearing plane of the vehicle on the road (see drawing).
	Application of an electronic light source control gear/variable intensity control		
	(a) being part of the lamp	:	N/A
	(b) being not part of the lamp	:	N/A
	Input voltage(s) supplied by an electronic light source control gear/variable intensity control	:	N/A

**Test Report No. : ISOQA-14-0132-R6**

Approval No. : 6R-01 3922  
Type : HU303-00-1  
Manufacturer : JUN YAN AUTO INDUSTRIAL CO., LTD.



Laboratory to ISOQA Technischer Dienst GmbH  
Web: [www.isoqa.org](http://www.isoqa.org)  
E-mail: [isoqa@isoqa.org](mailto:isoqa@isoqa.org)

Electronic light source control gear/variable intensity control manufacturer and identification number (when the light source control gear is part of the lamp but is not included into the lamp body) : N/A

Variable luminous intensity : NO

Sequential activation of light sources : NO

4.2. Position of the approval mark : on the LENS

4.3. Reason(s) for extension (if applicable) : N/A

**5. Appendices**

- 1. Appendix 1 Information document 1 page(s) in total
- 2. Appendix 2 Drawing 2 page(s) in total

**6. Statement of conformity**

The information folder respectively information document by the manufacturer and the type described therein are in compliance with the Test Specification mentioned above.

**ISOQA (Laboratory to ISOQA Technischer Dienst GmbH)**

Place : Taichung, Taiwan Date : 2015/2/2

Signature

Laboratory Manager - Chih-Hua Chang

**JUN YAN AUTO INDUSTRIAL CO., LTD.**

No.121, Wencheng Road,  
704 Tainan, Taiwan, Republic of China

TEL: 886-6-2812396

FAX: 886-6-2812397

**INFORMATION**

for Initial Application

Date: 2014/3/17

Manufacturer's Name and Address	JUN YAN AUTO INDUSTRIAL CO., LTD. No.121, Wencheng Road, 704 Tainan, Taiwan, Republic of China	
Trade name or mark	JUNYAN	
Type Name	HU303-00-1	
Material of Lens(es)	Sabic Lexan LS-2 111 with UVHC 3000 Coating	
Rate Voltage	12V	
Rate Wattage	see below	
Front Direction Indicator ( R6.01 )	Category	1
	Light Source	1 x PY21W, 12V, 21W
	Color of light emitted	Amber
	Color of lens	Clear
Front Position Lamp ( R7.02 )	Category	A
	Light Source	39 x LED, 12V, 3W
	Color of light emitted	White
	Color of lens	Clear
Daytime running lamp ( R87.00 )	Category	RL
	Light Source	39 x LED, 12V, 18W
	Color of light emitted	White
	Color of lens	Clear
Passing Beam ( R112.01 )	Category	HC
	Class	Class B
	Light Source	1 x H1, 12V, 55W
	Color of light emitted	White
	Color of lens	Clear
Driving Beam ( R112.01 )	Category	HR
	Class	Class B
	Light Source	1 x H1, 12V, 55W
	Color of light emitted	White
	Color of lens	Clear



NO	SYM	DATE	REVISIONS	DWN.	CHECK	APPR.

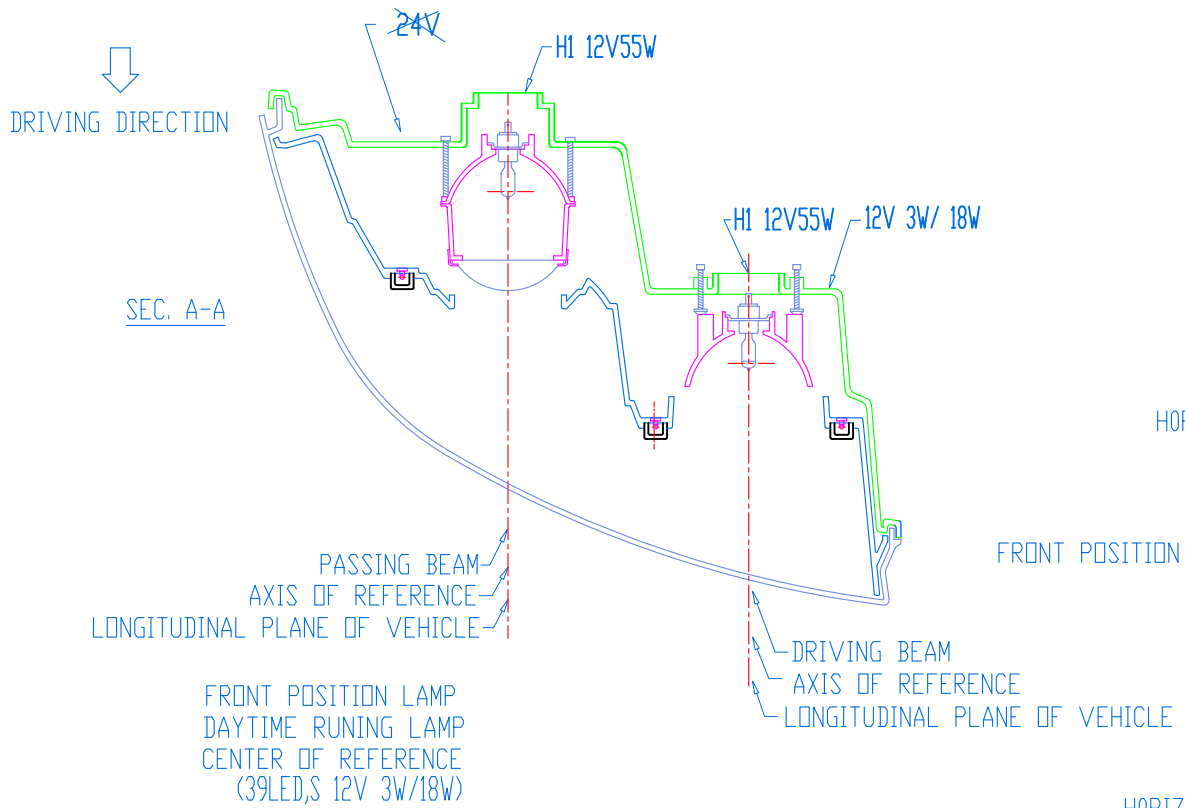

NOTE:1THIS DRAWING SHALL BE APPLIED FOR RIGHT HAND ONLY, AND LEFT HAND SHALL BE SYMMETRIC.  
2.LENS IS FIXED WITH HOUSING BY GLUE AND CLIPS.

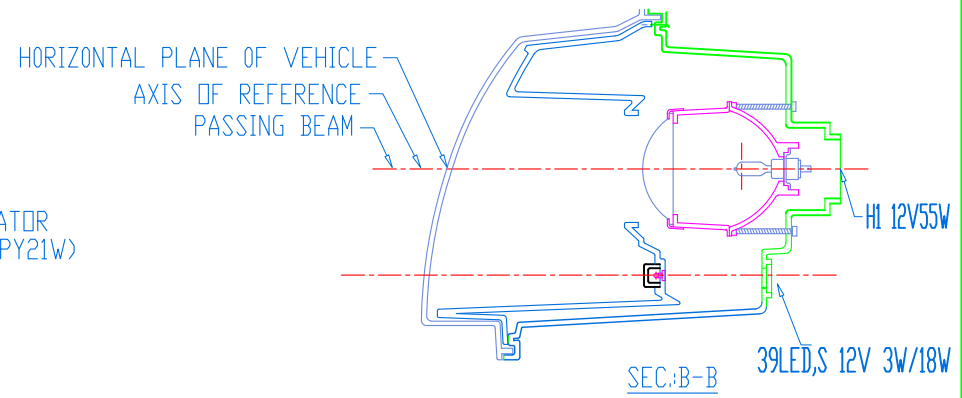
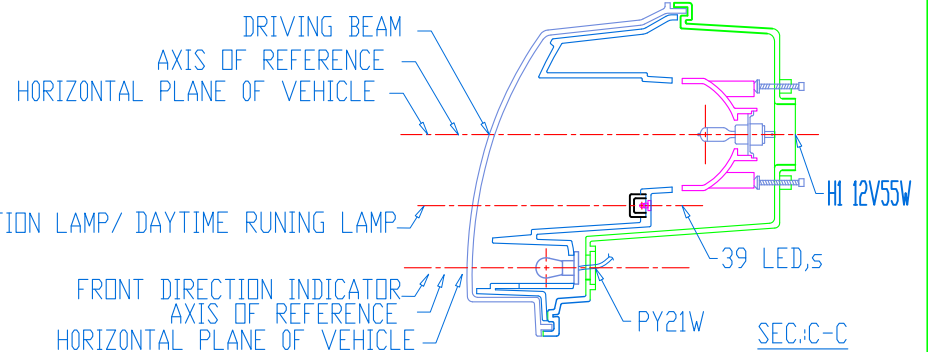
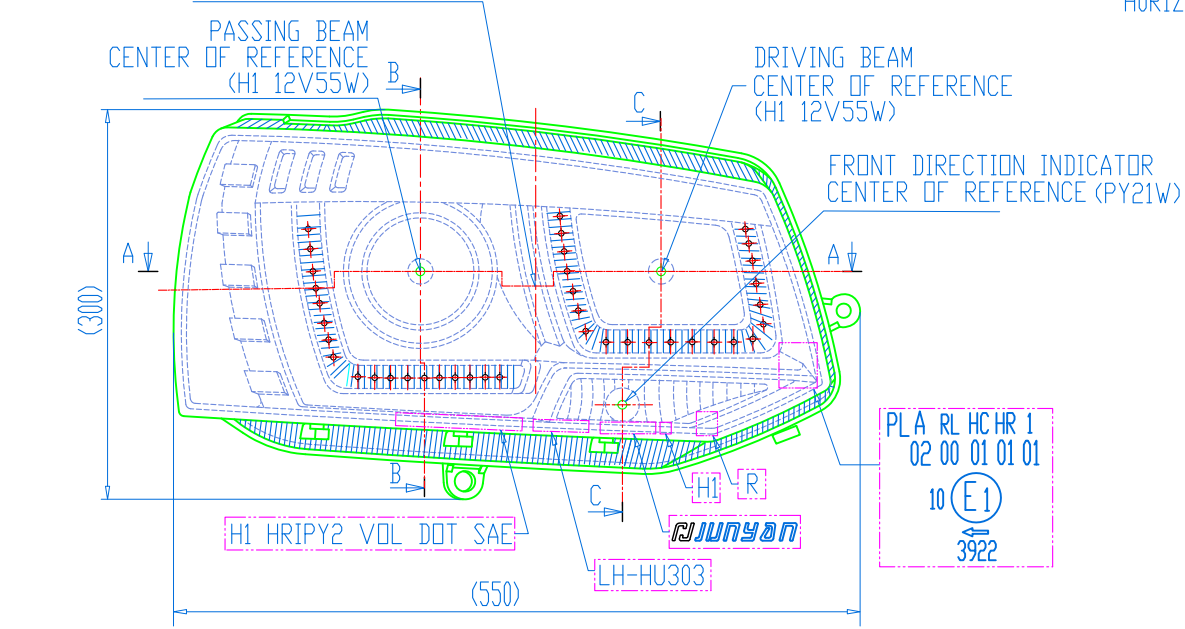

NO	FIG	NO.	CUSTOMER PART NO.	PART NO.	PART NAME	MATERIAL	QTY		REMARK
							R	L	
APPR.				CHECKED			SCL.	FREE	UNIT
	DGN BY			DWG BY			DATE	2014.12.30	
3rd ANGLE PROJECTION			PART NAME	HEAD LAMP			DRAW NO.	HU303-00-1(頭燈)	

JUNYAN AUTO INDUSTRIAL CO.,LTD.

# LDS-HU303

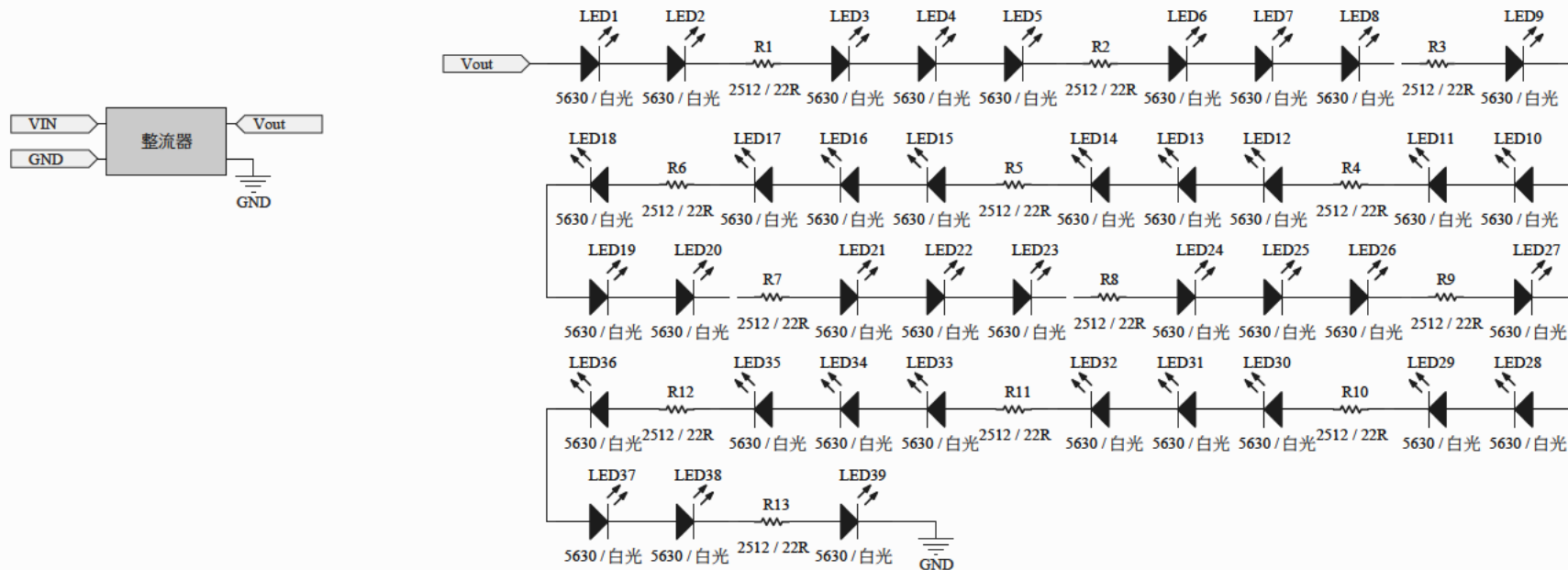

			Document Title: LDS-HU303		
			Document Number: PCB No.		
Sheet: Schematic Section			Revision: 00		
Size: A4		Draw By: ChiChin		Revision: 00	
Date: *		Time: *		Sheet 1 of 1	
File: Sheet1 SchDoc					



# Kraftfahrt-Bundesamt

DE-24932 Flensburg

---



## MITTEILUNG

ausgestellt von:

**Kraftfahrt-Bundesamt**

**über die Genehmigung**

für einen Typ einer **Begrenzungsleuchte** nach der Regelung Nr. 7  
**einschließlich der Änderung 02 Ergänzung 23**

## COMMUNICATION

issued by:

**Kraftfahrt-Bundesamt**

**concerning approval granted**

of a type of **front position lamp** pursuant to Regulation No. 7 **including  
amendment 02 supplement 23**

Nummer der Genehmigung: **023922**  
Approval No.:

Erweiterung Nr.: --  
Extension No.:

1. Fabrik- oder Handelsmarke der Einrichtung:  
Trade name or mark of the device:  
**JUNYAN**
2. Bezeichnung des Typs der Einrichtung durch den Hersteller:  
Manufacturer's name for the type of device:  
**HU303-00-1**
3. Name und Anschrift des Herstellers:  
Manufacturer's name and address:  
**JUN YAN AUTO INDUSTRIAL CO., LTD.**  
**TW-Tainan City 704**
4. Gegebenenfalls Name und Anschrift des Vertreters des Herstellers:  
If applicable, name and address of manufacturer's representative:  
**Integrated Services of Quality Assessment**  
**TW-41257 Da-Li, Taichung**



# Kraftfahrt-Bundesamt

DE-24932 Flensburg

---

2

Nummer der Genehmigung: 023922

Approval No.:

5. Zur Genehmigung vorgelegt am:

Submitted for approval on:

**09.02.2015**

6. Technischer Dienst, der die Prüfungen für die Genehmigung durchführt:

Technical service responsible for conducting approval tests:

**ISOQA Technischer Dienst GmbH**

**DE-76137 Karlsruhe**

7. Datum des Gutachtens:

Date of test report:

**02.02.2015**

8. Nummer des Gutachtens:

Number of test report:

**ISOQA-14-0132-R7**

9. Kurze Beschreibung:

Concise description:

9.1 Leuchtenkategorie: **A**

By category of lamp:

Zur Anbringung entweder außen oder innen oder beides: **außen**

For mounting either outside or inside or both: **outside**

Farbe des ausgestrahlten Lichts: **weiß**

Colour of light emitted: **white**

Anzahl, Kategorie und Art der Lichtquelle(n): **1 (39 LEDs, als eine Lichtquelle geschaltet/**

Number, category and kind of light source(s): **connected as one light source)**

Spannung und Leistung: **12V 3W**

Voltage and wattage:

Spezifischer Identifizierungskode des Lichtquellenmoduls: **entfällt**

Light source module specific identification code: **not applicable**

Nur für eine begrenzte Anbauhöhe von höchstens 750 mm über dem Boden: **nein**

Only for limited mounting height of equal to or less than 750 mm above the ground: **no**



Nummer der Genehmigung: 023922

Approval No.:

Geometrische Bedingungen für die Anbringung und mögliche Abweichungen, sofern zutreffend:

Geometrical conditions of installation und relating variations, if any:

**Bezugsachse parallel zur Fahrzeuglängsmittlebene und parallel zur Standfläche des Fahrzeugs auf der Fahrbahn (siehe anliegende Zeichnung)**  
**reference axis parallel to the median longitudinal plane of the vehicle and parallel to the bearing plane of the vehicle on the road (see attached drawing)**

Anwendung eines elektronischen Lichtquellen-Vorschaltgerätes/einer variablen Helligkeitssteuerung:

Application of an electronic light source control gear/variable intensity control:

(a) als Teil der Lampe: **nein**  
being part of the lamp: **no**

(b) nicht als Teil der Lampe: **nein**  
being not part of the lamp: **no**

Durch elektronisches Lichtquellen-Vorschaltgerät/variable Helligkeitssteuerung zugeführte Eingangsspannung:

Input voltage(s) supplied by an electronic light source control gear/variable intensity control:

**entfällt**  
**not applicable**

Hersteller und Identifizierungsnummer des elektronischen Lichtquellen-Vorschaltgerätes /der variablen Helligkeitssteuerung (falls das elektronische Lichtquellen-Vorschaltgerät Teil der Lampe ist und nicht im Lampengehäuse enthalten ist):

Electronic light source control gear/variable intensity control manufacturer and identification number (when the light source control gear is part of the lamp but is not included into the lamp body):

**entfällt**  
**not applicable**

Variable Beleuchtungsstärke: **nein**

Variable luminous intensity: **no**

9.2 Funktion(en) erzeugt durch eine abhängige Leuchte als Teil eines voneinander abhängigen Leuchtensystems:

Function(s) produced by an interdependent lamp forming part of an interdependent lamp system:

**Begrenzungsleuchte: nein**

**Front position lamp: no**



# Kraftfahrt-Bundesamt

DE-24932 Flensburg

4

Nummer der Genehmigung: 023922

Approval No.:

10. Anbringungsstelle des Genehmigungszeichens:  
Position of the approval mark:  
**auf der Abschlusscheibe**  
**on the lens**
11. Grund (Gründe) für die Erweiterung der Genehmigung (falls zutreffend):  
Reason(s) for extension (if applicable):  
**entfällt**  
**not applicable**
12. Genehmigung erteilt  
Approval **granted**
13. Ort: **DE-24932 Flensburg**  
Place:
14. Datum: **26.02.2015**  
Date:
15. Unterschrift: **Im Auftrag**  
Signature:

Stephan Marxsen



16. Das Verzeichnis der Unterlagen, die bei der Behörde hinterlegt sind, die die Genehmigung erteilt hat, ist dieser Mitteilung beigelegt und sind auf Anfrage erhältlich.  
The list of documents deposited with the Administrative service which has granted approval is annexed to this communication and may be obtained on request.

## **Nebenbestimmungen und Rechtsbehelfsbelehrung** **Collateral clauses and instruction on right to appeal**

- 1 **Prüfbericht mit Anlagen**  
**Test report with enclosures**



# Kraftfahrt-Bundesamt

DE-24932 Flensburg

---

5

Nummer der Genehmigung: 023922  
Approval No.:



# Kraftfahrt-Bundesamt

DE-24932 Flensburg

Nummer der Genehmigung: 023922

Approval No.:

**- Anlage -**

## Nebenbestimmungen und Rechtsbehelfsbelehrung

### Nebenbestimmungen

Jede Einrichtung, die dem genehmigten Typ entspricht, ist gemäß der angewendeten Vorschrift zu kennzeichnen.

Das Genehmigungszeichen lautet wie folgt:

**für linksseitigen Einbau**

**02 A**



**3922**

**für rechtsseitigen Einbau**

**02 A**



**3922**

Die Einzelerzeugnisse der reihenweisen Fertigung müssen mit den Genehmigungsunterlagen genau übereinstimmen. Änderungen an den Einzelerzeugnissen sind nur mit ausdrücklicher Zustimmung des Kraftfahrt-Bundesamtes gestattet.

Änderungen der Firmenbezeichnung, der Anschrift und der Fertigungsstätten sowie eines bei der Erteilung der Genehmigung benannten Zustellungsbevollmächtigten oder bevollmächtigten Vertreters sind dem Kraftfahrt-Bundesamt unverzüglich mitzuteilen.

Verstöße gegen diese Bestimmungen können zum Widerruf der Genehmigung führen und können überdies strafrechtlich verfolgt werden.

Die Genehmigung erlischt, wenn sie zurückgegeben oder entzogen wird, oder der genehmigte Typ den Rechtsvorschriften nicht mehr entspricht. Der Widerruf kann ausgesprochen werden, wenn die für die Erteilung und den Bestand der Genehmigung geforderten Voraussetzungen nicht mehr bestehen, wenn der Genehmigungsinhaber gegen die mit der Genehmigung verbundenen Pflichten – auch soweit sie sich aus den zu dieser Genehmigung zugeordneten besonderen Auflagen ergeben - verstößt oder wenn sich herausstellt, dass der genehmigte Typ den Erfordernissen der Verkehrssicherheit oder des Umweltschutzes nicht entspricht.

Das Kraftfahrt-Bundesamt kann jederzeit die ordnungsgemäße Ausübung der durch diese Genehmigung verliehenen Befugnisse, insbesondere die genehmigungsgerechte Fertigung sowie die Maßnahmen zur Übereinstimmung der Produktion, nachprüfen. Es kann zu diesem Zweck Proben entnehmen oder entnehmen lassen. Dem Kraftfahrt-Bundesamt und/oder seinen Beauftragten ist ungehinderter Zutritt zu Produktions- und Lagerstätten zu gewähren.

Die mit der Erteilung der Genehmigung verliehenen Befugnisse sind nicht übertragbar. Schutzrechte Dritter werden durch diese Genehmigung nicht berührt.





# Kraftfahrt-Bundesamt

DE-24932 Flensburg

---

2

Nummer der Genehmigung: 023922

Approval No.:

## **Rechtsbehelfsbelehrung**

Gegen diese Genehmigung kann innerhalb eines Monats nach Bekanntgabe Widerspruch erhoben werden. Der Widerspruch ist beim **Kraftfahrt-Bundesamt, Fördestraße 16, DE-24944 Flensburg**, schriftlich oder zur Niederschrift einzulegen.



# Kraftfahrt-Bundesamt

DE-24932 Flensburg

---

3

Nummer der Genehmigung: 023922

Approval No.:

**- Attachment -**

## **Collateral clauses and instruction on right to appeal**

### **Collateral clauses**

All equipment which corresponds to the approved type is to be identified according to the applied regulation.

The approval identification is as follows: - see German version -

The individual production of serial fabrication must be in exact accordance with the approval documents. Changes in the individual production are only allowed with express consent of the Kraftfahrt-Bundesamt.

Changes in the name of the company, the address and the manufacturing plant as well as one of the parties given the authority to delivery or authorised representative named when the approval was granted is to be immediately disclosed to the Kraftfahrt-Bundesamt.

Breach of this regulation can lead to recall of the approval and moreover can be legally prosecuted.

The approval expires if it is returned or withdrawn or if the type approved no longer complies with the legal requirements. The revocation can be made if the demanded requirements for issuance and the continuance of the approval no longer exist, if the holder of the approval violates the duties involved in the approval, also to the extent that they result from the assigned conditions to this approval, or if it is determined that the approved type does not comply with the requirements of traffic safety or environmental protection.

The Kraftfahrt-Bundesamt may check the proper exercise of the conferred authority taken from this approval at any time. In particular this means the compliant production as well as the measures for conformity of production. For this purpose samples can be taken or have taken. The employees or the representatives of the Kraftfahrt-Bundesamt may get unhindered access to the production and storage facilities.

The conferred authority contained with issuance of this approval is not transferable. Trade mark rights of third parties are not affected with this approval.

### **Instruction on right to appeal**

This approval can be appealed within one month after notification. The appeal is to be filed in writing or as a transcript at the **Kraftfahrt-Bundesamt, Fördestraße 16, DE-24944 Flensburg.**

**Test Report No. : ISOQA-14-0132-R7**

Approval No. : 7R-02 3922  
Type : HU303-00-1  
Manufacturer : JUN YAN AUTO INDUSTRIAL CO., LTD.



Laboratory to ISOQA Technischer Dienst GmbH  
Web: [www.isoqa.org](http://www.isoqa.org)  
E-mail: [isoqa@isoqa.org](mailto:isoqa@isoqa.org)

## TEST REPORT

Agreement concerning the adoption of uniform technical prescription for wheeled vehicles, equipment and parts which can be fitted and/or be used on wheeled vehicles and the conditions for reciprocal recognition of approvals granted on the basis of these prescriptions.

**Uniform provisions concerning the approval of front AND rear position lamps, ~~stop lamps AND end-outline marker lamps~~ for motor vehicles (except motor cycles) AND their trailers**

**Tested according ECE-R7, supplement 23, to 02 series of amendments of 9 October 2014**

Kind of device: Front Position Lamp, Category A

Approval status	
X	Application for granting of a type approval
	Application for an extension of type approval No.
	Reason for the extension:

**Test Report No. : ISOQA-14-0132-R7**

Approval No. : 7R-02 3922  
Type : HU303-00-1  
Manufacturer : JUN YAN AUTO INDUSTRIAL CO., LTD.



Laboratory to ISOQA Technischer Dienst GmbH  
Web: [www.isoqa.org](http://www.isoqa.org)  
E-mail: [isoqa@isoqa.org](mailto:isoqa@isoqa.org)

**0. General**

- 0.1. Make (trade name of manufacturer) : JUNYAN
- 0.2. Type : HU303-00-1
- 0.3. Class of the connecting device : Category A
- 0.4. Manufacturer's name and address : JUN YAN AUTO INDUSTRIAL CO., LTD.  
No.121, Wencheng Road,  
704 Tainan,  
Taiwan, Republic of China
- 0.5. Test laboratory : ISOQA (Laboratory to ISOQA Technischer Dienst GmbH)  
60, Yong Long Road,  
41257 Da-Li, Taichung  
Taiwan

**Test Report No. : ISOQA-14-0132-R7**

Approval No. : 7R-02 3922  
 Type : HU303-00-1  
 Manufacturer : JUN YAN AUTO INDUSTRIAL CO., LTD.



Laboratory to ISOQA Technischer Dienst GmbH  
 Web: [www.isoqa.org](http://www.isoqa.org)  
 E-mail: [isoqa@isoqa.org](mailto:isoqa@isoqa.org)

**1. Test object (s)**

## 1.1. Information :

Material of Lens	Sabic Lexan LS-2 111 with UVHC 3000 Coating	
Material of Housing	Plastic	
Material of Reflector	Plastic	
Rated Voltage	12V	
Front Position Lamp	Category	A
	Light Source	39 x LED, 12V, 3W
	Color of light emitted	White
	Color of lens	Clear
	Visibility	The visibility angles are asymmetrical, the horizontal arrow is required.
	Grouped with	Front direction indicator, Driving beam and Passing beam
	Combined with	--
	Incorporated with	Daytime running lamp

1.2. Location of Marking : see Appendix 2

## 1.3. Remark(s) :

1.3.1 There are no objections against the variants that may be described in the Information folder respectively the information document by the manufacturer because adversely effects are not expected.

The lamps are part of the same assembly of grouped, combined or reciprocally incorporated lamps. Each of these lamps satisfies the requirements of the relevant regulation.

## Test Report No. : ISOQA-14-0132-R7

Approval No. : 7R-02 3922  
Type : HU303-00-1  
Manufacturer : JUN YAN AUTO INDUSTRIAL CO., LTD.



Laboratory to ISOQA Technischer Dienst GmbH  
Web: [www.isoqa.org](http://www.isoqa.org)  
E-mail: [isoqa@isoqa.org](mailto:isoqa@isoqa.org)

## 2. Test Specification

2.1. Place of test : Laboratory of ISOQA in Taiwan

2.2. Date of test : 2014/9/18

2.3. Date of receipt of test device(s) : 2014/9/18

### 2.4. Test results :

#### 2.4.1. Markings (according to paragraph 3 of R7-02)

a. trade name or mark	Complies	see Appendix 2
b. Light sources	Complies	see Appendix 2
c. Space reserved for the approval mark	Complies	see Appendix 2
d. Light source module(s)	Not Applicable	

#### 2.4.2. General Specifications (according to paragraph 5 of R7-02)

a. Conformity of specifications	Complies	
b. Design and construction for satisfactory operation	Complies	
c. Light sources module	Not Applicable	
d. replaceable filament lamp(s)	Not Applicable	
e. Variable intensity control	Not Applicable	

#### 2.4.3. Intensity of light emitted (according to paragraph 6 of R7-02)

a. Light distribution	Complies	see 3.1
b. Visibility	Complies	see 3.1
c. failure of more than one light source	Not Applicable	see 3.1 & 2.5.1

2.4.4. colour of light emitted (according to paragraph 8 of ECE R7-02) : Complies see 3.2

### 2.5. Remark (s)

2.5.1 According to manufacturer's technical description all light sources are connected in series, therefore they are considered to be one light source.



**Test Report No. : ISOQA-14-0132-R7**

Approval No. : 7R-02 3922  
 Type : HU303-00-1  
 Manufacturer : JUN YAN AUTO INDUSTRIAL CO., LTD.

**3.2. Color of light emitted test record**

Type Name	: HU303-00-1	Engineer	: Bo Yang Lee
Function	: Front Position Lamp	Category	: A
Test Voltage	: 13.5V	Light Source	: 39 x LED
Test Distance	: 2.904 m	Current	: same as photometric test

Function (s)	Color of light emitted	Sample 1 (LHM)		Sample 2 (RHM)		Result
		x	y	x	y	
Front Position Lamp	White	0.3183	0.3314	0.3220	0.3363	PASS

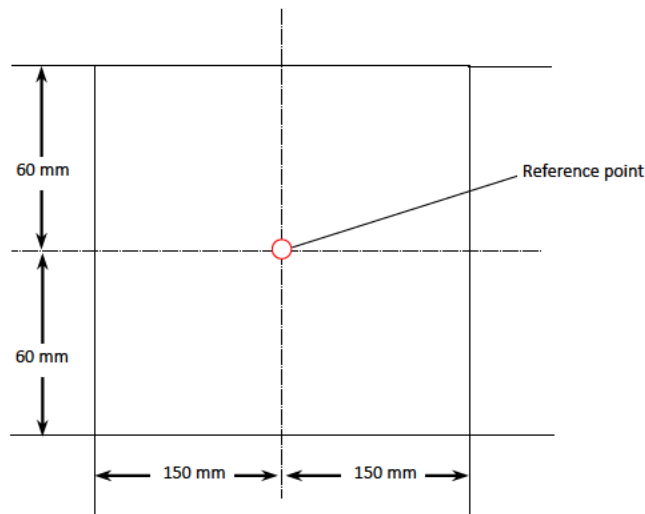
**3.3. Determination of the apparent surface**



## Test Report No. : ISOQA-14-0132-R7

Approval No. : 7R-02 3922  
Type : HU303-00-1  
Manufacturer : JUN YAN AUTO INDUSTRIAL CO., LTD.



Laboratory to ISOQA Technischer Dienst GmbH  
Web: [www.isoqa.org](http://www.isoqa.org)  
E-mail: [isoqa@isoqa.org](mailto:isoqa@isoqa.org)

### 4. Communication

Concerning : APPROVAL GRANTED

of a type of device pursuant to Regulation No. 7

Approval No. 7R-02 3922 Extension No. 00

#### 4.1. Concise description

4.1.1 By category of lamp	:	A
For mounting either outside or inside or both	:	outside
Colour of light emitted	:	White
Number, category and kind of light source(s)	:	1 non replaceable light source (39 LEDs connected as 1 light sources)
Voltage and wattage	:	12V 3W
Light source module specific identification code	:	N/A
Only for installation on M1 and/or N1 category vehicles	:	NO
Only for limited mounting height of equal to or less than 750mm above the ground	:	NO
Geometrical conditions of installation and relating variations, if any	:	Reference axis parallel to the median longitudinal plane of the vehicle and parallel to the bearing plane of the vehicle on the road (see drawing).
Application of an electronic light source control gear/variable intensity control	:	
(a) being part of the lamp	:	N/A
(b) being not part of the lamp	:	N/A
Input voltage(s) supplied by an electronic light source control gear/variable intensity control	:	N/A

**Test Report No. : ISOQA-14-0132-R7**

Approval No. : 7R-02 3922  
Type : HU303-00-1  
Manufacturer : JUN YAN AUTO INDUSTRIAL CO., LTD.



Laboratory to ISOQA Technischer Dienst GmbH  
Web: [www.isoqa.org](http://www.isoqa.org)  
E-mail: [isoqa@isoqa.org](mailto:isoqa@isoqa.org)

Electronic light source control gear/variable intensity control manufacturer and identification number (when the light source control gear is part of the lamp but is not included into the lamp body) : N/A

Variable luminous intensity : NO

4.1.2 Function(s) produced by an interdependent lamp forming part of an interdependent lamp system

Front position lamp : NO

R1 Rear position lamp : N/A

R2 Rear position lamp : N/A

S1 Stop lamp : N/A

S2 Stop lamp : N/A

S3 Stop lamp : N/A

S4 Stop lamp : N/A

End-outline marker lamp : N/A

4.2. Position of the approval mark : on the LENS

4.3. Reason(s) for extension (if applicable) : N/A

**Test Report No. : ISOQA-14-0132-R7**

Approval No. : 7R-02 3922  
Type : HU303-00-1  
Manufacturer : JUN YAN AUTO INDUSTRIAL CO., LTD.



Laboratory to ISOQA Technischer Dienst GmbH  
Web: [www.isoqa.org](http://www.isoqa.org)  
E-mail: [isoqa@isoqa.org](mailto:isoqa@isoqa.org)

**5. Appendices**

- |                                    |                    |
|------------------------------------|--------------------|
| 1. Appendix 1 Information document | 1 page(s) in total |
| 2. Appendix 2 Drawing              | 2 page(s) in total |

**6. Statement of conformity**

The information folder respectively information document by the manufacturer and the type described therein are in compliance with the Test Specification mentioned above.

**ISOQA (Laboratory to ISOQA Technischer Dienst GmbH)**

Place : Taichung, Taiwan      Date : 2015/2/2

Signature

A handwritten signature in black ink that reads 'Arthur Chang'. The signature is written in a cursive, flowing style.

Laboratory Manager - Chih-Hua Chang

**JUN YAN AUTO INDUSTRIAL CO., LTD.**

No.121, Wencheng Road,  
704 Tainan, Taiwan, Republic of China

TEL: 886-6-2812396

FAX: 886-6-2812397

**INFORMATION**

for Initial Application

Date: 2014/3/17

Manufacturer's Name and Address	JUN YAN AUTO INDUSTRIAL CO., LTD. No.121, Wencheng Road, 704 Tainan, Taiwan, Republic of China	
Trade name or mark	JUNYAN	
Type Name	HU303-00-1	
Material of Lens(es)	Sabic Lexan LS-2 111 with UVHC 3000 Coating	
Rate Voltage	12V	
Rate Wattage	see below	
Front Direction Indicator ( R6.01 )	Category	1
	Light Source	1 x PY21W, 12V, 21W
	Color of light emitted	Amber
	Color of lens	Clear
Front Position Lamp ( R7.02 )	Category	A
	Light Source	39 x LED, 12V, 3W
	Color of light emitted	White
	Color of lens	Clear
Daytime running lamp ( R87.00 )	Category	RL
	Light Source	39 x LED, 12V, 18W
	Color of light emitted	White
	Color of lens	Clear
Passing Beam ( R112.01 )	Category	HC
	Class	Class B
	Light Source	1 x H1, 12V, 55W
	Color of light emitted	White
	Color of lens	Clear
Driving Beam ( R112.01 )	Category	HR
	Class	Class B
	Light Source	1 x H1, 12V, 55W
	Color of light emitted	White
	Color of lens	Clear

NO	SYM	DATE	REVISIONS	DWN.	CHECK	APPR.

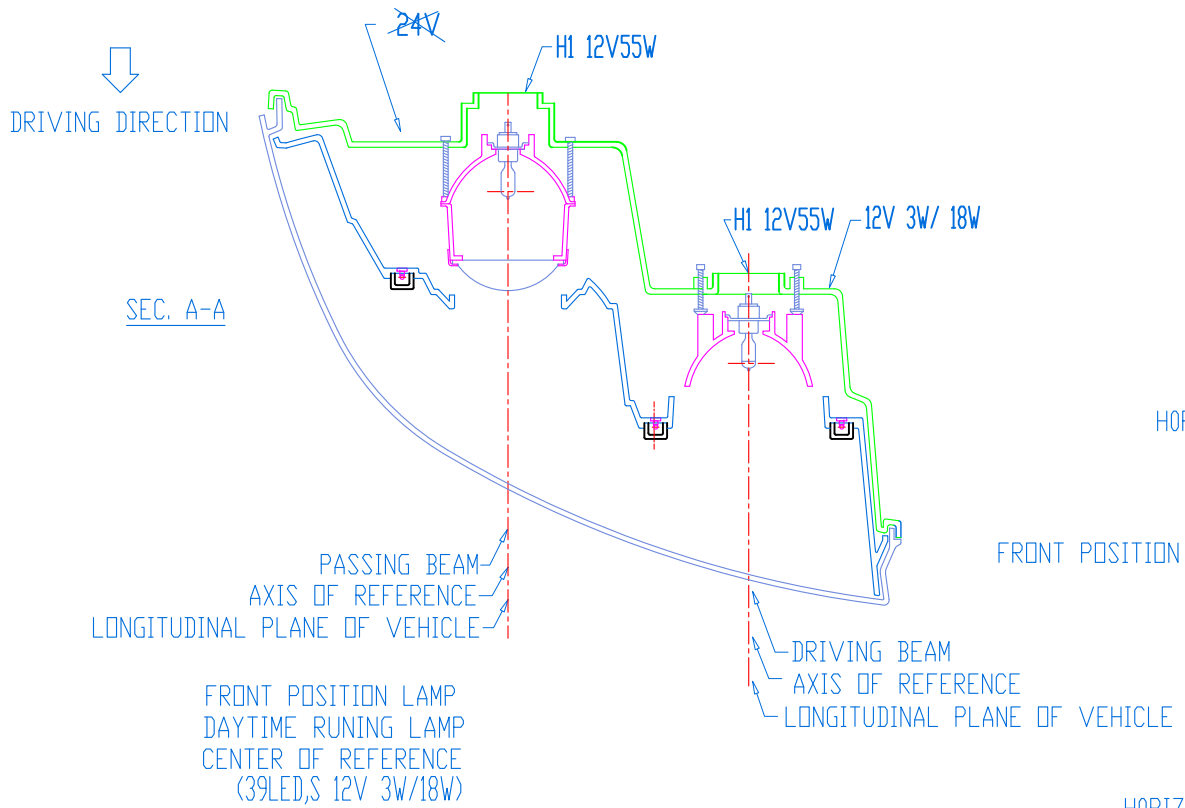

NOTE:1 THIS DRAWING SHALL BE APPLIED FOR RIGHT HAND ONLY, AND LEFT HAND SHALL BE SYMMETRIC.  
2. LENS IS FIXED WITH HOUSING BY GLUE AND CLIPS.

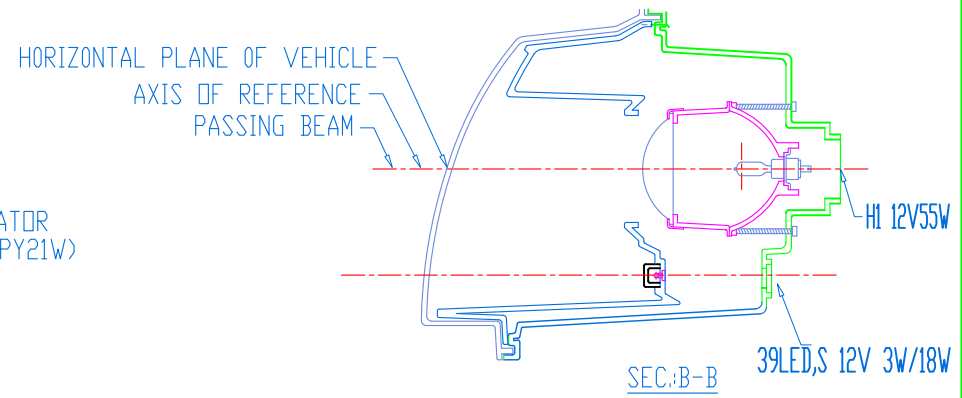
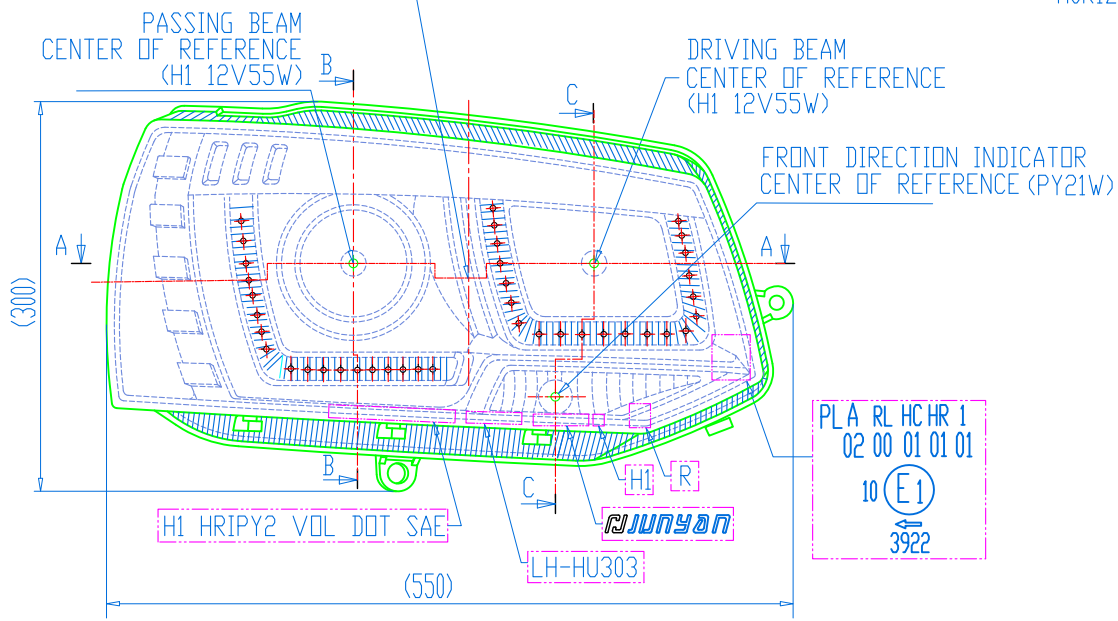
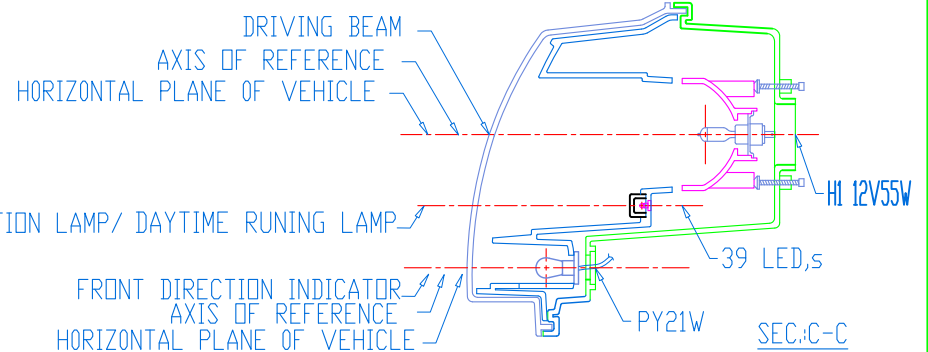

NO	FIG	NO.	CUSTOMER PART NO.	PART NO.	PART NAME	MATERIAL	QTY		REMARK
							R	L	
APPR.				CHECKED			SCL.	FREE	UNIT
	DGN BY			DWG BY			DATE	2014.12.30	
3rd ANGLE PROJECTION			PART NAME	HEAD LAMP			DRAW NO.	HU303-00-1(頭燈)	

JUNYAN AUTO INDUSTRIAL CO.,LTD.

# LDS-HU303

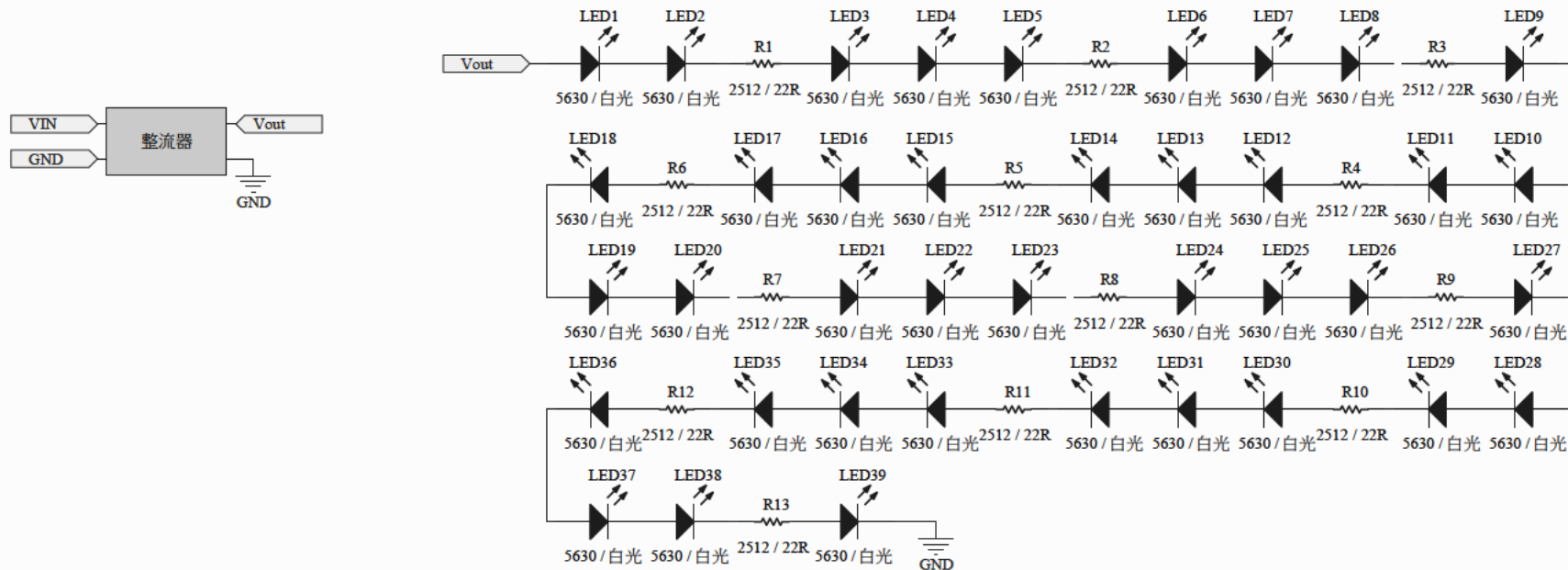

	Document Title: <b>LDS-HU303</b>		
	Document Number: <b>PCB No.</b>		
	Sheet: <b>Schematic Section</b>		
	Size: <b>A4</b>	Draw By: <b>ChiChin</b>	Revision: <b>00</b>
	Date: *	Time: *	Sheet <b>1</b> of <b>1</b>
File: <b>Sheet1 SchDoc</b>			



# Kraftfahrt-Bundesamt

DE-24932 Flensburg

---

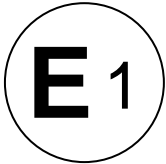

## MITTEILUNG

ausgestellt von:

**Kraftfahrt-Bundesamt**

**über die Genehmigung**

für einen Typ einer Leuchte für Tagfahrlicht nach der Regelung Nr. 87  
**einschließlich der Ergänzung 17**

## COMMUNICATION

issued by:

**Kraftfahrt-Bundesamt**

**concerning approval granted**

of a type of daytime running lamp pursuant to Regulation No. 87  
**including supplement 17**

Nummer der Genehmigung: **003922**  
Approval No.:

Erweiterung Nr.: --  
Extension No.:

1. Fabrik- oder Handelsmarke der Tagfahrleuchte:  
Trade name or mark of the daytime running lamp:  
**JUNYAN**
2. Bezeichnung des Typs der Tagfahrleuchte durch den Hersteller:  
Manufacturer's name for the type of daytime running lamp:  
**HU303-00-1**
3. Name und Anschrift des Herstellers:  
Manufacturer's name and address:  
**JUN YAN AUTO INDUSTRIAL CO., LTD.**  
**TW-Tainan City 704**
4. Gegebenenfalls Name und Anschrift des Vertreters des Herstellers:  
If applicable, name and address of the manufacturer's representative:  
**Integrated Services of Quality Assessment**  
**TW-41257 Da-Li, Taichung**



# Kraftfahrt-Bundesamt

DE-24932 Flensburg

---

2

Nummer der Genehmigung: 003922

Approval No.:

5. Zur Genehmigung eingereicht am:  
Submitted for approval on:  
**09.02.2015**

6. Technischer Dienst:  
Technical service:  
**ISOQA Technischer Dienst GmbH**  
**DE-76137 Karlsruhe**

7. Datum des Gutachtens des Technischen Dienstes:  
Date of test report issued by that service:  
**02.02.2015**

8. Nummer des Gutachtens des Technischen Dienstes:  
Number of test report issued by that service:  
**ISOQA-14-0132-R87**

9. Kurze Beschreibung:  
Concise description:

Leuchtenkategorie: **RL**  
By category of lamp:

Anzahl, Kategorie(n) und Art der Lichtquelle(n): **1 (39 LEDs, als eine Lichtquelle geschaltet/  
connected as one light source)**  
Number, category and kind of light sources:

Spannung und Leistung: **12V 18W**  
Voltage and wattage:

Anwendung eines elektronischen Lichtquellen-Vorschaltgerätes:  
Application of an electronic light source control gear:

(a) als Teil der Lampe: **nein**  
being part of the lamp: **no**

(b) nicht als Teil der Lampe: **nein**  
being not part of the lamp: **no**

Durch elektronisches Lichtquellen-Vorschaltgerät zugeführte Eingangsspannung:  
Input voltage(s) supplied by an electronic light source control gear:  
**entfällt**  
**not applicable**





# Kraftfahrt-Bundesamt

DE-24932 Flensburg

---

3

Nummer der Genehmigung: 003922

Approval No.:

Hersteller und Identifizierungsnummer des elektronischen Lichtquellen-Vorschaltgerätes (falls das elektronische Lichtquellen-Vorschaltgerät Teil der Lampe ist und nicht im Lampengehäuse enthalten ist):

Electronic light source control gear manufacturer and identification number (when the light source control gear is part of the lamp but is not included into the lamp body):

**entfällt**

**not applicable**

10. Die Tagfahrleuchte ist als abhängiges Leuchtensystem ausgeführt: **nein**  
The daytime running lamp is designed as an interdependent lamp: **no**

Anzahl der abhängigen Leuchten innerhalb des abhängigen Leuchtensystems: **entfällt**  
Quantity of interdependent lamps within the interdependent lamp system: **not applicable**

11. Anbringungsstelle des Genehmigungszeichens:  
Position of the approval mark:  
**auf der Abschlusscheibe**  
**on the lens**

12. Gründe für die Erweiterung (falls zutreffend):  
Reason(s) for extension (if applicable):  
**entfällt**  
**not applicable**

13. Genehmigung **erteilt**  
Approval **granted**



# Kraftfahrt-Bundesamt

DE-24932 Flensburg

---

4

Nummer der Genehmigung: 003922

Approval No.:

14. Ort: **DE-24932 Flensburg**  
Place:
15. Datum: **26.02.2015**  
Date:
16. Unterschrift: **Im Auftrag**  
Signature:

Stephan Marxsen



17. Die Liste der Unterlagen, die bei der Genehmigungsbehörde hinterlegt und auf Anfrage erhältlich sind, liegt dieser Mitteilung bei.  
The list of documents deposited with the Administrative service which has granted approval is annexed to this communication and may be obtained on request.

**Nebenbestimmungen und Rechtsbehelfsbelehrung**  
**Collateral clauses and instruction on right to appeal**

- 1 Prüfbericht mit Anlagen**  
**Test report with enclosures**



# Kraftfahrt-Bundesamt

DE-24932 Flensburg

---

Nummer der Genehmigung: 003922

Approval No.:

**- Anlage -**

## **Nebenbestimmungen und Rechtsbehelfsbelehrung**

### **Nebenbestimmungen**

Jede Einrichtung, die dem genehmigten Typ entspricht, ist gemäß der angewendeten Vorschrift zu kennzeichnen.

Das Genehmigungszeichen lautet wie folgt:

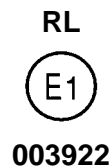

Die Einzelerzeugnisse der reihenweisen Fertigung müssen mit den Genehmigungsunterlagen genau übereinstimmen. Änderungen an den Einzelerzeugnissen sind nur mit ausdrücklicher Zustimmung des Kraftfahrt-Bundesamtes gestattet.

Änderungen der Firmenbezeichnung, der Anschrift und der Fertigungsstätten sowie eines bei der Erteilung der Genehmigung benannten Zustellungsbevollmächtigten oder bevollmächtigten Vertreters sind dem Kraftfahrt-Bundesamt unverzüglich mitzuteilen.

Verstöße gegen diese Bestimmungen können zum Widerruf der Genehmigung führen und können überdies strafrechtlich verfolgt werden.

Die Genehmigung erlischt, wenn sie zurückgegeben oder entzogen wird, oder der genehmigte Typ den Rechtsvorschriften nicht mehr entspricht. Der Widerruf kann ausgesprochen werden, wenn die für die Erteilung und den Bestand der Genehmigung geforderten Voraussetzungen nicht mehr bestehen, wenn der Genehmigungsinhaber gegen die mit der Genehmigung verbundenen Pflichten – auch soweit sie sich aus den zu dieser Genehmigung zugeordneten besonderen Auflagen ergeben - verstößt oder wenn sich herausstellt, dass der genehmigte Typ den Erfordernissen der Verkehrssicherheit oder des Umweltschutzes nicht entspricht.

Das Kraftfahrt-Bundesamt kann jederzeit die ordnungsgemäße Ausübung der durch diese Genehmigung verliehenen Befugnisse, insbesondere die genehmigungsgerechte Fertigung sowie die Maßnahmen zur Übereinstimmung der Produktion, nachprüfen. Es kann zu diesem Zweck Proben entnehmen oder entnehmen lassen. Dem Kraftfahrt-Bundesamt und/oder seinen Beauftragten ist ungehinderter Zutritt zu Produktions- und Lagerstätten zu gewähren.

Die mit der Erteilung der Genehmigung verliehenen Befugnisse sind nicht übertragbar. Schutzrechte Dritter werden durch diese Genehmigung nicht berührt.



# Kraftfahrt-Bundesamt

DE-24932 Flensburg

---

2

Nummer der Genehmigung: 003922

Approval No.:

## **Rechtsbehelfsbelehrung**

Gegen diese Genehmigung kann innerhalb eines Monats nach Bekanntgabe Widerspruch erhoben werden. Der Widerspruch ist beim **Kraftfahrt-Bundesamt, Fördestraße 16, DE-24944 Flensburg**, schriftlich oder zur Niederschrift einzulegen.



# Kraftfahrt-Bundesamt

DE-24932 Flensburg

---

3

Nummer der Genehmigung: 003922

Approval No.:

**- Attachment -**

## **Collateral clauses and instruction on right to appeal**

### **Collateral clauses**

All equipment which corresponds to the approved type is to be identified according to the applied regulation.

The approval identification is as follows: - see German version -

The individual production of serial fabrication must be in exact accordance with the approval documents. Changes in the individual production are only allowed with express consent of the Kraftfahrt-Bundesamt.

Changes in the name of the company, the address and the manufacturing plant as well as one of the parties given the authority to delivery or authorised representative named when the approval was granted is to be immediately disclosed to the Kraftfahrt-Bundesamt.

Breach of this regulation can lead to recall of the approval and moreover can be legally prosecuted.

The approval expires if it is returned or withdrawn or if the type approved no longer complies with the legal requirements. The revocation can be made if the demanded requirements for issuance and the continuance of the approval no longer exist, if the holder of the approval violates the duties involved in the approval, also to the extent that they result from the assigned conditions to this approval, or if it is determined that the approved type does not comply with the requirements of traffic safety or environmental protection.

The Kraftfahrt-Bundesamt may check the proper exercise of the conferred authority taken from this approval at any time. In particular this means the compliant production as well as the measures for conformity of production. For this purpose samples can be taken or have taken. The employees or the representatives of the Kraftfahrt-Bundesamt may get unhindered access to the production and storage facilities.

The conferred authority contained with issuance of this approval is not transferable. Trade mark rights of third parties are not affected with this approval.

### **Instruction on right to appeal**

This approval can be appealed within one month after notification. The appeal is to be filed in writing or as a transcript at the **Kraftfahrt-Bundesamt, Fördestraße 16, DE-24944 Flensburg.**

**Test Report No. : ISOQA-14-0132-R87**

Approval No. : 87R-00 3922  
Type : HU303-00-1  
Manufacturer : JUN YAN AUTO INDUSTRIAL CO., LTD.



Laboratory to ISOQA Technischer Dienst GmbH  
Web: [www.isoqa.org](http://www.isoqa.org)  
E-mail: [isoqa@isoqa.org](mailto:isoqa@isoqa.org)

## TEST REPORT

Agreement concerning the adoption of uniform technical prescription for wheeled vehicles, equipment and parts which can be fitted and/or be used on wheeled vehicles and the conditions for reciprocal recognition of approvals granted on the basis of these prescriptions.

**Uniform provisions concerning the approval of daytime running lamps for power-driven vehicles**

**Tested according ECE-R87, supplement 17, to original version of 03 November 2013**

Kind of device: Daytime running lamp, Category RL

Approval status	
X	Application for granting of a type approval
	Application for an extension of type approval No.
	Reason for the extension:

**Test Report No. : ISOQA-14-0132-R87**

Approval No. : 87R-00 3922  
Type : HU303-00-1  
Manufacturer : JUN YAN AUTO INDUSTRIAL CO., LTD.



Laboratory to ISOQA Technischer Dienst GmbH  
Web: [www.isoqa.org](http://www.isoqa.org)  
E-mail: [isoqa@isoqa.org](mailto:isoqa@isoqa.org)

**0. General**

- 0.1. Make (trade name of manufacturer) : JUNYAN
- 0.2. Type : HU303-00-1
- 0.3. Class of the connecting device : RL
- 0.4. Manufacturer's name and address : JUN YAN AUTO INDUSTRIAL CO., LTD.  
No.121, Wencheng Road,  
704 Tainan,  
Taiwan, Republic of China
- 0.5. Test laboratory : ISOQA (Laboratory to ISOQA Technischer Dienst GmbH)  
60, Yong Long Road,  
41257 Da-Li, Taichung  
Taiwan

**Test Report No. : ISOQA-14-0132-R87**

Approval No. : 87R-00 3922  
Type : HU303-00-1  
Manufacturer : JUN YAN AUTO INDUSTRIAL CO., LTD.



Laboratory to ISOQA Technischer Dienst GmbH  
Web: [www.isoqa.org](http://www.isoqa.org)  
E-mail: [isoqa@isoqa.org](mailto:isoqa@isoqa.org)

**1. Test object (s)**

## 1.1. Information :

Material of Lens	Sabic Lexan LS-2 111 with UVHC 3000 Coating	
Material of Housing	Plastic	
Material of Reflector	Plastic	
Rated Voltage	12V	
Daytime Running Lamp	Category	RL
	Light Source	39 x LED, 12V, 18W
	Color of light emitted	White
	Color of lens	Clear
	Grouped with	Front direction indicator, Driving beam and Passing beam
	Combined with	--
	Incorporated with	Front position lamp

## 1.2. Location of Marking : see Appendix 2

## 1.3. Remark(s) :

1.3.1 There are no objections against the variants that may be described in the Information folder respectively the information document by the manufacturer because adversely effects are not expected.

The lamps are part of the same assembly of grouped, combined or reciprocally incorporated lamps. Each of these lamps satisfies the requirements of the relevant regulation.



**Test Report No. : ISOQA-14-0132-R87**

Approval No. : 87R-00 3922  
Type : HU303-00-1  
Manufacturer : JUN YAN AUTO INDUSTRIAL CO., LTD.



Laboratory to ISOQA Technischer Dienst GmbH  
Web: [www.isoqa.org](http://www.isoqa.org)  
E-mail: [isoqa@isoqa.org](mailto:isoqa@isoqa.org)

**2. Test Specification**

- 2.1. Place of test : Laboratory of ISOQA in Taiwan
- 2.2. Date of test : 2014/9/18 ~ 2014/12/17
- 2.3. Date of receipt of test device(s) : 2014/9/18

**2.4. Test results :****2.4.1. Markings (according to paragraph 4 of R87-00)**

- |   |                |                |
|---|----------------|----------------|
| a. trade name or mark                   | Complies       | see Appendix 2 |
| b. Light sources                        | Complies       | see Appendix 2 |
| c. Space reserved for the approval mark | Complies       | see Appendix 2 |
| d. Light source module(s)               | Not Applicable |                |

**2.4.2. General Specifications (according to paragraph 6 of R87-00)**

- |   |                |  |
|---|----------------|--|
| a. Conformity of specifications                       | Complies       |  |
| b. Design and construction for satisfactory operation | Complies       |  |
| c. Light sources module                               | Not Applicable |  |
| d. replaceable filament lamp(s)                       | Not Applicable |  |
| e. Variable intensity control                         | Not Applicable |  |

**2.4.3. Intensity of light emitted (according to paragraph 7 of R87-00)**

- |  |                |                 |
|--|----------------|-----------------|
| a. Light distribution                    | Complies       | see 3.1         |
| b. Visibility                            | Complies       | see 3.1         |
| c. failure of more than one light source | Not Applicable | see 3.1 & 2.5.2 |

**Test Report No. : ISOQA-14-0132-R87**

Approval No. : 87R-00 3922  
Type : HU303-00-1  
Manufacturer : JUN YAN AUTO INDUSTRIAL CO., LTD.



Laboratory to ISOQA Technischer Dienst GmbH  
Web: [www.isoqa.org](http://www.isoqa.org)  
E-mail: [isoqa@isoqa.org](mailto:isoqa@isoqa.org)

---

2.4.4.	apparent of surface (according to paragraph 8 of ECE R87-00)	Complies	141	cm <sup>2</sup>
2.4.5.	colour of light emitted (according to paragraph 9 of ECE R87-00)	Complies	see 3.2	
2.4.6.	heat resistance test (according to paragraph 11 of ECE R87-00)	Complies	see 2.5.1	
2.5.	Remark (s)	--		
2.5.1	After the test no distortion, deformation, cracking or colour modification been perceived.			
2.5.2	According to manufacturer's technical description all light sources are connected in series, therefore they are considered to be one light source.			



**Test Report No. : ISOQA-14-0132-R87**

Approval No. : 87R-00 3922  
 Type : HU303-00-1  
 Manufacturer : JUN YAN AUTO INDUSTRIAL CO., LTD.

**3.2. Color of light emitted test record**

Type Name	: HU303-00-1	Engineer	: Bo Yang Lee
Function	: Daytime running lamp	Category	: RL
Test Voltage	: 13.5V	Light Source	: 39 x LED
Test Distance	: 2.904	Current	: 1.262 A / 1.290 A

Function (s)	Color of light emitted	Sample 1		Sample 2		Result
		x	y	x	y	
Daytime running lamp	White	0.3140	0.3214	0.3178	0.3269	PASS

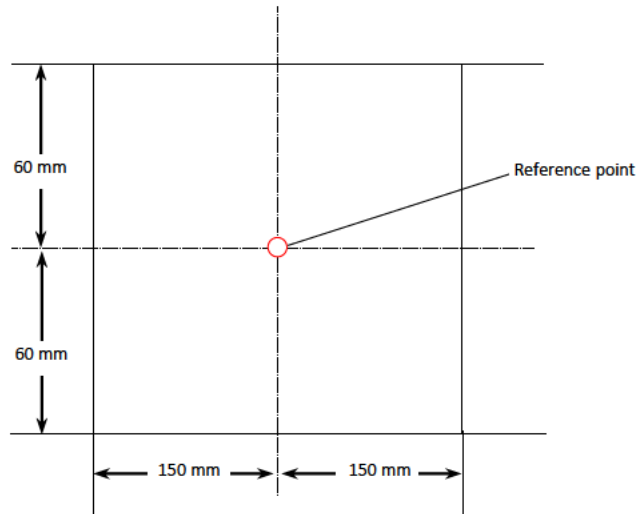
**3.3. Determination of the apparent surface**

## Test Report No. : ISOQA-14-0132-R87

Approval No. : 87R-00 3922  
Type : HU303-00-1  
Manufacturer : JUN YAN AUTO INDUSTRIAL CO., LTD.



Laboratory to ISOQA Technischer Dienst GmbH  
Web: [www.isoqa.org](http://www.isoqa.org)  
E-mail: [isoqa@isoqa.org](mailto:isoqa@isoqa.org)

### 4. Communication

Concerning : APPROVAL GRANTED

of a type of device pursuant to Regulation No. 87

Approval No. 87R-00 3922 Extension No. 00

#### 4.1. Concise description

- 4.1.1 By category of lamp : RL
- Number, category and kind of light source(s) : 1 non replaceable light source (39 LEDs connected as 1 light sources)
- Voltage and wattage : 12V 18W
- Application of an electronic light source control gear
- (a) being part of the lamp : N/A
- (b) being not part of the lamp : N/A
- Input voltage(s) supplied by an electronic light source control gear/variable intensity control : N/A
- Electronic light source control gear manufacturer and identification number (when the light source control gear is part of the lamp but is not included into the lamp body): : N/A
- 4.2. The daytime running lamp is designed as an interdependent lamp system yes/no : NO
- The interdependent lamp system consists of 2/3 interdependent lamps. : N/A
- 4.2. Position of the approval mark : on the LENS
- 4.3. Reason(s) for extension (if applicable) : N/A

**Test Report No. : ISOQA-14-0132-R87**

Approval No. : 87R-00 3922  
Type : HU303-00-1  
Manufacturer : JUN YAN AUTO INDUSTRIAL CO., LTD.



Laboratory to ISOQA Technischer Dienst GmbH  
Web: [www.isoqa.org](http://www.isoqa.org)  
E-mail: [isoqa@isoqa.org](mailto:isoqa@isoqa.org)

**5. Appendices**

- |                                    |                    |
|------------------------------------|--------------------|
| 1. Appendix 1 Information document | 1 page(s) in total |
| 2. Appendix 2 Drawing              | 2 page(s) in total |

**6. Statement of conformity**

The information folder respectively information document by the manufacturer and the type described therein are in compliance with the Test Specification mentioned above.

**ISOQA (Laboratory to ISOQA Technischer Dienst GmbH)**

Place : Taichung, Taiwan                      Date : 2015/2/2

Signature

A handwritten signature in black ink that reads 'Archer Chang'.

Laboratory Manager - Chih-Hua Chang

**JUN YAN AUTO INDUSTRIAL CO., LTD.**

No.121, Wencheng Road,  
704 Tainan, Taiwan, Republic of China

TEL: 886-6-2812396

FAX: 886-6-2812397

**INFORMATION**

for Initial Application

Date: 2014/3/17

Manufacturer's Name and Address	JUN YAN AUTO INDUSTRIAL CO., LTD. No.121, Wencheng Road, 704 Tainan, Taiwan, Republic of China	
Trade name or mark	JUNYAN	
Type Name	HU303-00-1	
Material of Lens(es)	Sabic Lexan LS-2 111 with UVHC 3000 Coating	
Rate Voltage	12V	
Rate Wattage	see below	
Front Direction Indicator ( R6.01 )	Category	1
	Light Source	1 x PY21W, 12V, 21W
	Color of light emitted	Amber
	Color of lens	Clear
Front Position Lamp ( R7.02 )	Category	A
	Light Source	39 x LED, 12V, 3W
	Color of light emitted	White
	Color of lens	Clear
Daytime running lamp ( R87.00 )	Category	RL
	Light Source	39 x LED, 12V, 18W
	Color of light emitted	White
	Color of lens	Clear
Passing Beam ( R112.01 )	Category	HC
	Class	Class B
	Light Source	1 x H1, 12V, 55W
	Color of light emitted	White
	Color of lens	Clear
Driving Beam ( R112.01 )	Category	HR
	Class	Class B
	Light Source	1 x H1, 12V, 55W
	Color of light emitted	White
	Color of lens	Clear

NO	SYM	DATE	REVISIONS	DWN.	CHECK	APPR.

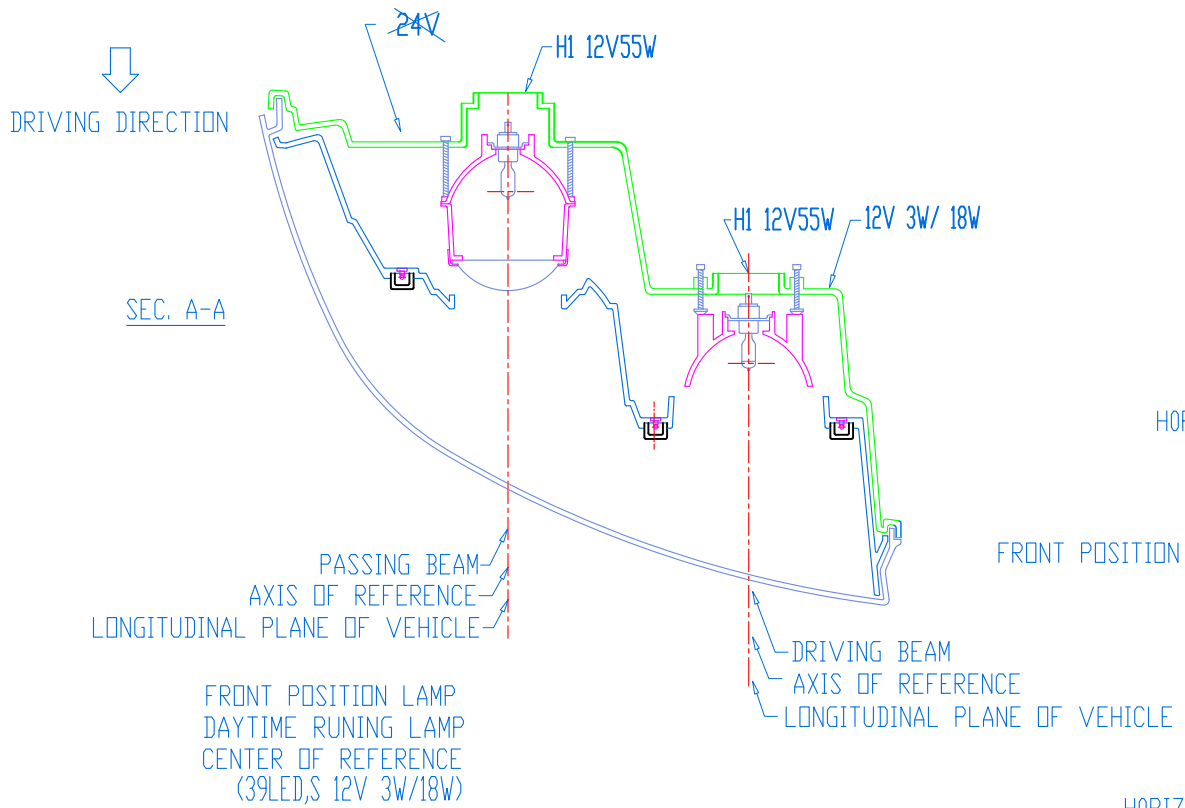

NOTE:1 THIS DRAWING SHALL BE APPLIED FOR RIGHT HAND ONLY, AND LEFT HAND SHALL BE SYMMETRIC.  
2. LENS IS FIXED WITH HOUSING BY GLUE AND CLIPS.

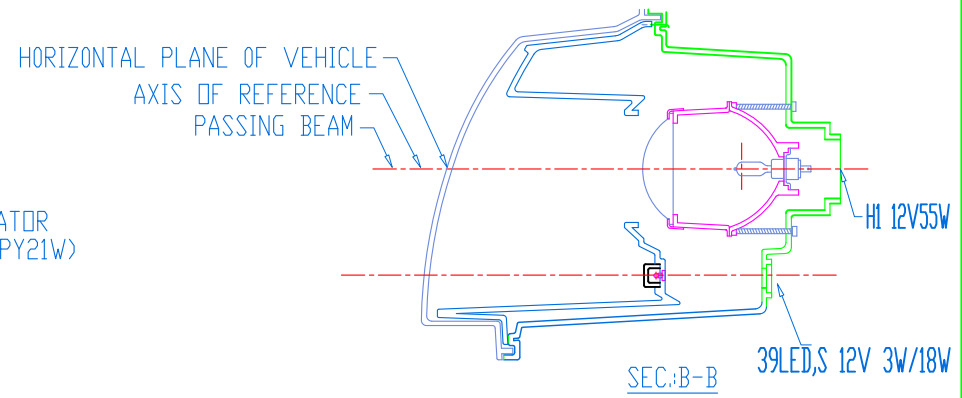
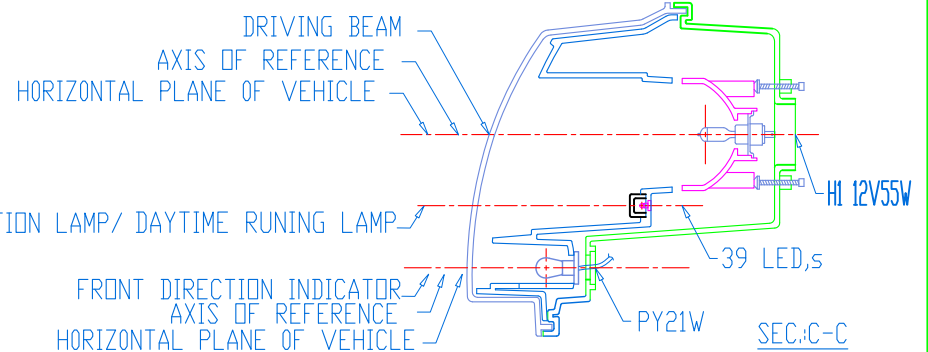
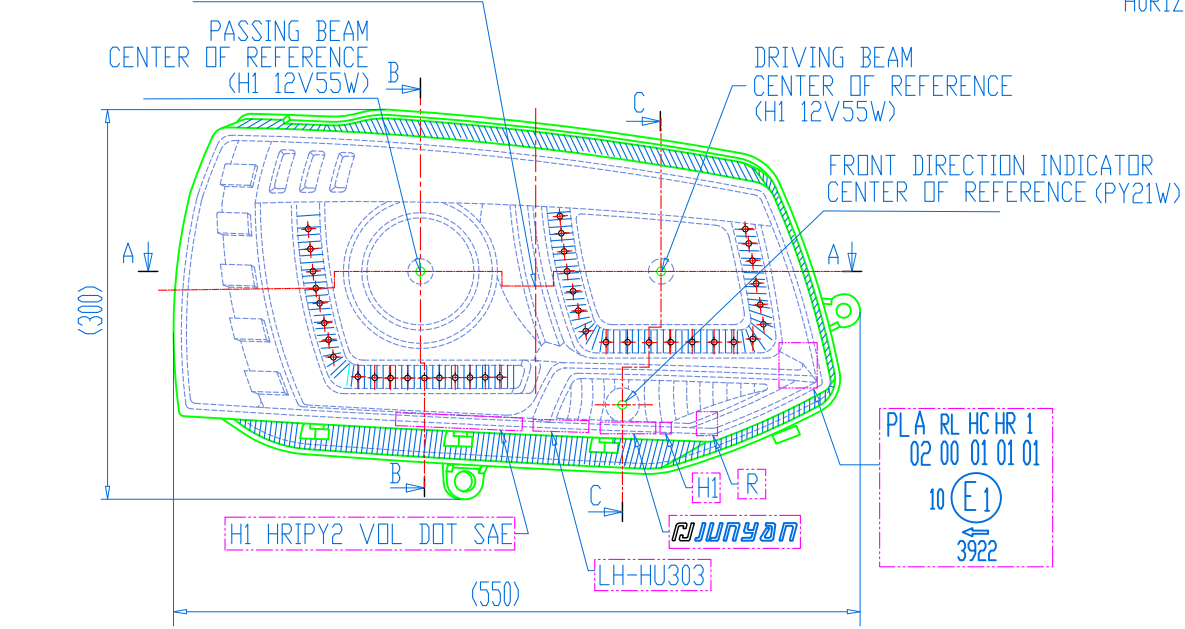



NO	FIG	NO.	CUSTOMER PART NO.	PART NO.	PART NAME	MATERIAL	QTY		REMARK
							R	L	
MARK OF INDICATION	REVISIONS	APPR.		CHECKED		SCL.	FREE	UNIT	mm
	GENERALLY-USED PARTS	DGN BY		DWG BY		DATE			2014.12.30
3rd ANGLE PROJECTION			PART NAME	HEAD LAMP			DRAW NO.	HU303-00-1(頭燈)	

JUNYAN AUTO INDUSTRIAL CO.,LTD.

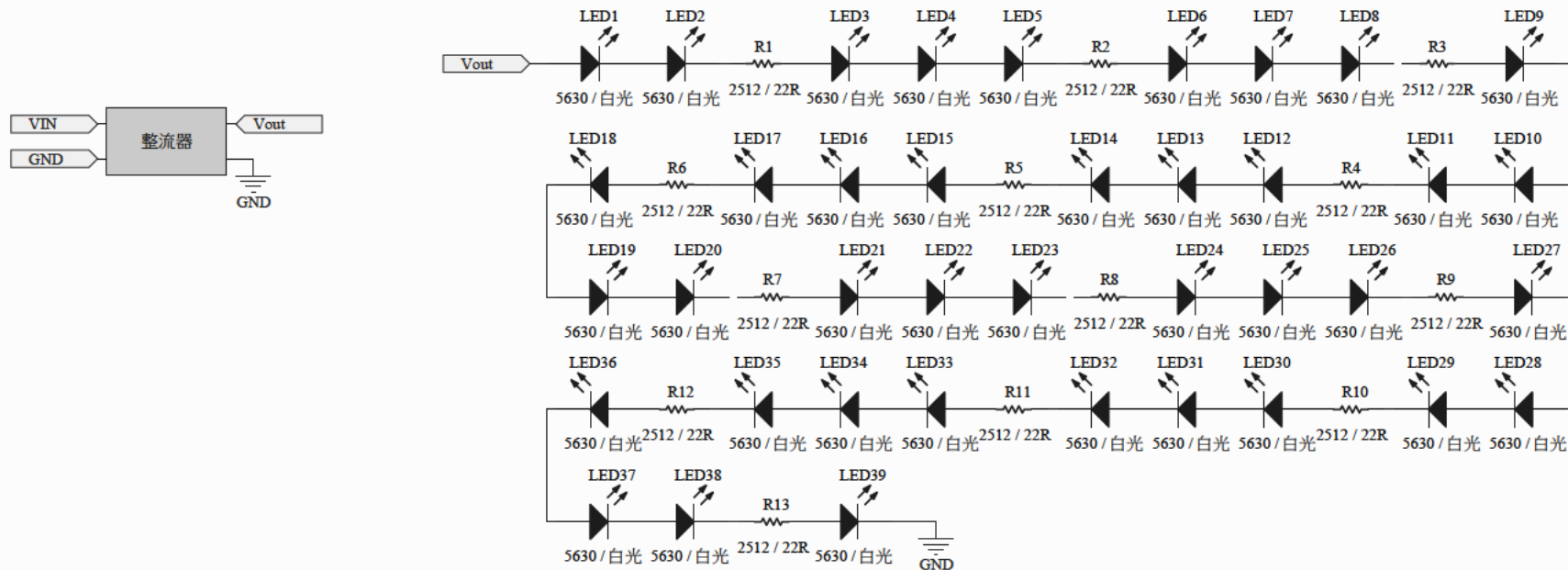

# LDS-HU303



			Document Title: LDS-HU303		
			Document Number: PCB No.		
			Sheet: Schematic Section		
Size: A4		Draw By: ChiChin		Revision: 00	
Date: *		Time: *		Sheet 1 of 1	
File: Sheet1 SchDoc					



# Kraftfahrt-Bundesamt

DE-24932 Flensburg

---



## MITTEILUNG

ausgestellt von:

**Kraftfahrt-Bundesamt**

**über die Genehmigung**

für einen Scheinwerfertyp nach der Regelung Nr. 112  
**einschließlich der Änderung 01 Ergänzung 4**

## COMMUNICATION

issued by:

**Kraftfahrt-Bundesamt**

**concerning approval granted**

of a type of headlamp pursuant to Regulation No. 112  
**including amendment 01 supplement 4**

Nummer der Genehmigung: **013922**  
Approval No.:

Erweiterung Nr.: --  
Extension No.:

1. Fabrik- oder Handelsmarke der Einrichtung:  
Trade name or mark of the device:  
**JUNYAN**
2. Bezeichnung des Typs durch den Hersteller:  
Manufacturer's name for the type of device:  
**HU303-00-1**
3. Name und Anschrift des Herstellers:  
Manufacturer's name and address:  
**JUN YAN AUTO INDUSTRIAL CO., LTD.**  
**TW-Tainan City 704**
4. Gegebenenfalls Name und Anschrift des Vertreters des Herstellers:  
If applicable, name and address of manufacturer's representative:  
**Integrated Services of Quality Assessment**  
**TW-41257 Da-Li, Taichung**



# Kraftfahrt-Bundesamt

DE-24932 Flensburg

---

2

Nummer der Genehmigung: 013922

Approval No.:

5. Vorgelegt zur Genehmigung am:

Submitted for approval on:

**09.02.2015**

6. Technischer Dienst, der die Prüfungen für die Genehmigung durchführt:

Technical service responsible for conducting approval tests:

**ISOQA Technischer Dienst GmbH**

**DE-76137 Karlsruhe**

7. Datum des Gutachtens des Technischen Dienstes:

Date of report issued by that service:

**02.02.2015**

8. Nummer des Gutachtens des Technischen Dienstes:

Number of report issued by that service:

**ISOQA-14-0132-R112-HC**

9. Kurzbeschreibung:

Brief description:

Kategorie nach der entsprechenden Aufschrift: **HC PL**

Category as described by the relevant marking:

Anzahl und Kategorie(n) der Glühlampe(n): **1 x H1**

Number and category(s) of filament lamp(s):

Für das Abblendlicht verwendeter Bezugslichtstrom (lm): **entfällt**

Reference luminous flux used for the principal passing beam (lm): **not applicable**

Betrieb des Abblendlichts bei ungefähr (V): **entfällt**

Principal passing beam operated at approximately (V): **not applicable**

Maßnahmen entsprechend Punkt 5.8. dieser Regelung:

Measures according to paragraph 5.8. of this Regulation:

**Absenkung des Scheinwerfers**

**downward adjustment of the beam**

Anzahl und spezifische Kennzeichnungs-codes der LED-Module und für jedes LED-Modul eine Angabe, ob es auswechselbar ist oder nicht: **entfällt**

Number and specific identification code(s) of LED module(s) and for each LED module a statement whether it is replaceable or not: **not applicable**



# Kraftfahrt-Bundesamt

DE-24932 Flensburg

---

3

Nummer der Genehmigung: 013922

Approval No.:

Anzahl und spezifische Kennzeichnungs-codes des elektronischen Lichtquellen-Vorschaltgerätes:

Number and specific identification code(s) of electronic light source control gear(s):

**entfällt**

**not applicable**

Objektiver Gesamtlichtstrom, wie beschrieben im Punkt 5.9., überschreitet 2.000 Lumen:

Total objective luminous flux as described in paragraph 5.9. exceeds 2.000 lumen:

**nein**

**no**

Die Justierung der "Hell-Dunkel-Grenze" ist festgestellt worden bei: **10 m**

The adjustment of the "cut-off" has been determined at:

Die Ermittlung der minimalen Schärfe der "Hell-Dunkel-Grenze" ist durchgeführt worden bei:

The determination of the minimum sharpness of the "cut-off" has been carried out at:

**entfällt**

**not applicable**

10. Stelle, an der das Genehmigungszeichen angebracht ist:

Approval mark position:

**auf der Abschluss-scheibe**

**on the lens**

11. Grund (Gründe) für die Erweiterung der Genehmigung:

Reason(s) for extension of approval:

**entfällt**

**not applicable**

12. Die Genehmigung wird **erteilt**

Approval **granted**



# Kraftfahrt-Bundesamt

DE-24932 Flensburg

---

4

Nummer der Genehmigung: 013922

Approval No.:

13. Ort: **DE-24932 Flensburg**  
Place:
14. Datum: **26.02.2015**  
Date:
15. Unterschrift: **Im Auftrag**  
Signature:

Stephan Marxsen



16. Ein Verzeichnis der Unterlagen, die bei der Behörde hinterlegt sind, die die Genehmigung erteilt hat, und die bei Bedarf angefordert werden können, ist dieser Mitteilung beigelegt.  
The list of documents deposited with the Administrative Service which has granted approval is annexed to this communication and may be obtained on request.

## **Nebenbestimmungen und Rechtsbehelfsbelehrung** **Collateral clauses and instruction on right to appeal**

- 1 Prüfbericht mit Anlagen**  
**Test report with enclosures**



# Kraftfahrt-Bundesamt

DE-24932 Flensburg

---

Nummer der Genehmigung: 013922

Approval No.:

**- Anlage -**

## **Nebenbestimmungen und Rechtsbehelfsbelehrung**

### **Nebenbestimmungen**

Jede Einrichtung, die dem genehmigten Typ entspricht, ist gemäß der angewendeten Vorschrift zu kennzeichnen.

Das Genehmigungszeichen lautet wie folgt:

**HC PL**

**01**



**3922**

Die Einzelerzeugnisse der reihenweisen Fertigung müssen mit den Genehmigungsunterlagen genau übereinstimmen. Änderungen an den Einzelerzeugnissen sind nur mit ausdrücklicher Zustimmung des Kraftfahrt-Bundesamtes gestattet.

Änderungen der Firmenbezeichnung, der Anschrift und der Fertigungsstätten sowie eines bei der Erteilung der Genehmigung benannten Zustellungsbevollmächtigten oder bevollmächtigten Vertreters sind dem Kraftfahrt-Bundesamt unverzüglich mitzuteilen.

Verstöße gegen diese Bestimmungen können zum Widerruf der Genehmigung führen und können überdies strafrechtlich verfolgt werden.

Die Genehmigung erlischt, wenn sie zurückgegeben oder entzogen wird, oder der genehmigte Typ den Rechtsvorschriften nicht mehr entspricht. Der Widerruf kann ausgesprochen werden, wenn die für die Erteilung und den Bestand der Genehmigung geforderten Voraussetzungen nicht mehr bestehen, wenn der Genehmigungsinhaber gegen die mit der Genehmigung verbundenen Pflichten – auch soweit sie sich aus den zu dieser Genehmigung zugeordneten besonderen Auflagen ergeben - verstößt oder wenn sich herausstellt, dass der genehmigte Typ den Erfordernissen der Verkehrssicherheit oder des Umweltschutzes nicht entspricht.

Das Kraftfahrt-Bundesamt kann jederzeit die ordnungsgemäße Ausübung der durch diese Genehmigung verliehenen Befugnisse, insbesondere die genehmigungsgerechte Fertigung sowie die Maßnahmen zur Übereinstimmung der Produktion, nachprüfen. Es kann zu diesem Zweck Proben entnehmen oder entnehmen lassen. Dem Kraftfahrt-Bundesamt und/oder seinen Beauftragten ist ungehinderter Zutritt zu Produktions- und Lagerstätten zu gewähren.

Die mit der Erteilung der Genehmigung verliehenen Befugnisse sind nicht übertragbar. Schutzrechte Dritter werden durch diese Genehmigung nicht berührt.



# Kraftfahrt-Bundesamt

DE-24932 Flensburg

---

2

Nummer der Genehmigung: 013922

Approval No.:

## **Rechtsbehelfsbelehrung**

Gegen diese Genehmigung kann innerhalb eines Monats nach Bekanntgabe Widerspruch erhoben werden. Der Widerspruch ist beim **Kraftfahrt-Bundesamt, Fördestraße 16, DE-24944 Flensburg**, schriftlich oder zur Niederschrift einzulegen.



# Kraftfahrt-Bundesamt

DE-24932 Flensburg

---

3

Nummer der Genehmigung: 013922

Approval No.:

**- Attachment -**

## **Collateral clauses and instruction on right to appeal**

### **Collateral clauses**

All equipment which corresponds to the approved type is to be identified according to the applied regulation.

The approval identification is as follows: - see German version -

The individual production of serial fabrication must be in exact accordance with the approval documents. Changes in the individual production are only allowed with express consent of the Kraftfahrt-Bundesamt.

Changes in the name of the company, the address and the manufacturing plant as well as one of the parties given the authority to delivery or authorised representative named when the approval was granted is to be immediately disclosed to the Kraftfahrt-Bundesamt.

Breach of this regulation can lead to recall of the approval and moreover can be legally prosecuted.

The approval expires if it is returned or withdrawn or if the type approved no longer complies with the legal requirements. The revocation can be made if the demanded requirements for issuance and the continuance of the approval no longer exist, if the holder of the approval violates the duties involved in the approval, also to the extent that they result from the assigned conditions to this approval, or if it is determined that the approved type does not comply with the requirements of traffic safety or environmental protection.

The Kraftfahrt-Bundesamt may check the proper exercise of the conferred authority taken from this approval at any time. In particular this means the compliant production as well as the measures for conformity of production. For this purpose samples can be taken or have taken. The employees or the representatives of the Kraftfahrt-Bundesamt may get unhindered access to the production and storage facilities.

The conferred authority contained with issuance of this approval is not transferable. Trade mark rights of third parties are not affected with this approval.

### **Instruction on right to appeal**

This approval can be appealed within one month after notification. The appeal is to be filed in writing or as a transcript at the **Kraftfahrt-Bundesamt, Fördestraße 16, DE-24944 Flensburg.**



**Test Report No. : ISOQA-14-0132-R112-HC**

Approval No. : 112R-01 3922  
Type : HU303-00-1  
Manufacturer : JUN YAN AUTO INDUSTRIAL CO., LTD.



Laboratory to ISOQA Technischer Dienst GmbH  
Web: [www.isoqa.org](http://www.isoqa.org)  
E-mail: [isoqa@isoqa.org](mailto:isoqa@isoqa.org)

## TEST REPORT

Agreement concerning the adoption of uniform technical prescription for wheeled vehicles, equipment and parts which can be fitted and/or be used on wheeled vehicles and the conditions for reciprocal recognition of approvals granted on the basis of these prescriptions.

**Uniform provisions concerning the approval of motor vehicle headlamps emitting an asymmetrical passing beam ~~or driving beam or both~~ and equipped with filament lamps and /-or LED Modules**

**Tested according ECE-R112, Supplement 4 to 01 series of 15 July 2013**

Kind of device: Headlamp for Right-hand traffic system asymmetrical Passing Beam, Class B

Approval status	
X	Application for granting of a type approval
	Application for an extension of type approval No.
	Reason for the extension:

## Test Report No. : ISOQA-14-0132-R112-HC

Approval No. : 112R-01 3922  
Type : HU303-00-1  
Manufacturer : JUN YAN AUTO INDUSTRIAL CO., LTD.



Laboratory to ISOQA Technischer Dienst GmbH  
Web: [www.isoqa.org](http://www.isoqa.org)  
E-mail: [isoqa@isoqa.org](mailto:isoqa@isoqa.org)

### 0. General

- 0.1. Make (trade name of manufacturer) : JUNYAN
- 0.2. Type : HU303-00-1
- 0.3. Class of the connecting device : Class B
- 0.4. Manufacturer's name and address : JUN YAN AUTO INDUSTRIAL CO., LTD.  
No.121, Wencheng Road,  
704 Tainan,  
Taiwan, Republic of China
- 0.5. Test laboratory : ISOQA (Laboratory to ISOQA Technischer Dienst GmbH)  
60, Yong Long Road,  
41257 Da-Li, Taichung  
Taiwan

**Test Report No. : ISOQA-14-0132-R112-HC**

Approval No. : 112R-01 3922  
 Type : HU303-00-1  
 Manufacturer : JUN YAN AUTO INDUSTRIAL CO., LTD.



Laboratory to ISOQA Technischer Dienst GmbH  
 Web: [www.isoqa.org](http://www.isoqa.org)  
 E-mail: [isoqa@isoqa.org](mailto:isoqa@isoqa.org)

**1. Test object (s)**

## 1.1. Information :

Material of Lens	Sabic Lexan LS-2 111 with UVHC 3000 Coating	
Material of Housing	Plastic	
Material of Reflector	Plastic	
Rated Voltage	12V	
Passing Beam	Category	HC
	Traffic System	Right-hand traffic system
	Light Source	1 x H1, 12V, 55W
	Color of light emitted	White
	Color of lens	Clear
	Grouped with	Direction indicator, front position lamp, daytime running lamp and driving Beam Headlamp
	Combined with	--
	Incorporated with	--

1.2. Location of Marking : see Appendix 2

## 1.3. Remark(s) :

1.3.1. There are no objections against the variants that may be described in the Information folder respectively the information document by the manufacturer because adversely effects are not expected.

The lamps are part of the same assembly of grouped, combined or reciprocally incorporated lamps. Each of these lamps satisfies the requirements of the relevant regulation.

1.3.2. tests of plastic material please se : LTIK Report No. PMT 060 and PMT 060 N1

## Test Report No. : ISOQA-14-0132-R112-HC

Approval No. : 112R-01 3922  
Type : HU303-00-1  
Manufacturer : JUN YAN AUTO INDUSTRIAL CO., LTD.



Laboratory to ISOQA Technischer Dienst GmbH  
Web: [www.isoqa.org](http://www.isoqa.org)  
E-mail: [isoqa@isoqa.org](mailto:isoqa@isoqa.org)

## 2. Test Specification

- 2.1. Place of test : Laboratory of ISOQA in Taiwan
- 2.2. Date of test : 2014/9/18 ~ 2014/12/17
- 2.3. Date of receipt of test device(s) : 2014/9/18

## 2.4. Test results

### 2.4.1. Markings (according to paragraph 3 and 4 of ECE R112-01)

- |    |  |                |                |
|----|--|----------------|----------------|
| a. | Trade name or mark   | Complies       | see Appendix 2 |
| b. | Light sources  | Complies       | see Appendix 2 |
| c. | Space reserved for the approval mark   | Complies       | see Appendix 2 |
| d. | LED module(s)  | Not Applicable |                |
| e. | Marking for headlamp designed to meet the requirements of both traffic systems or left-hand traffic system only. | Not Applicable |                |
| f. | A symbol consisting of the number 24 crossed out by an oblique cross (x)   | Complies       | see Appendix 2 |

### 2.4.2. General Specifications (according to paragraph 5 of ECE R112-01)

- |    |  |                |                                      |
|----|--|----------------|--------------------------------------|
| a. | Conformity the specifications  | Complies       |                                      |
| b. | Design and construction for satisfactory operation                       | Complies       |                                      |
| c. | Light source   | Complies       |                                      |
| d. | Setting of headlamp designed for both traffic systems                    | Not Applicable |                                      |
| e. | Tests for stability of photometric performance of headlamps in operation | Complies       | see 3.4                              |
| f. | Test for plastic lens  | Complies       | see 3.5.                             |
| g. | Alternative driving and/or passing beam                                  | Not Applicable |                                      |
| h. | Illumination configuration for different traffic conditions              | Complies       | (b) Downward adjustment of the beam. |

## Test Report No. : ISOQA-14-0132-R112-HC

Approval No. : 112R-01 3922  
Type : HU303-00-1  
Manufacturer : JUN YAN AUTO INDUSTRIAL CO., LTD.



Laboratory to ISOQA Technischer Dienst GmbH  
Web: [www.isoqa.org](http://www.isoqa.org)  
E-mail: [isoqa@isoqa.org](mailto:isoqa@isoqa.org)

2.4.3.	Illumination (according to paragraph 6 of ECE R112-01)		
a.	General Provision	Complies	
b.	Passing Beam	Complies	see 3.1
c.	Driving beams	Not Applicable	
d.	Adjustable reflectors	Complies	see 3.2
e.	Photo-receptor	Complies	
2.4.4.	Colour (according to paragraph 7 of ECE R112-01)	Complies	see 3.3
2.4.5	LED Module (according to Annex10 of ECE R112-01)		
a.	Ageing	Not Applicable	
b.	colour rendering - Red content	Not Applicable	
c.	uv-radiation	Not Applicable	
d.	temperature stability - Illuminance	Not Applicable	
e.	temperature stability - Colour	Not Applicable	
f.	objective luminous flux	Not Applicable	
2.5.	Remark (s)	--	

**Test Report No. : ISOQA-14-0132-R112-HC**

Approval No. : 112R-01 3922  
 Type : HU303-00-1  
 Manufacturer : JUN YAN AUTO INDUSTRIAL CO., LTD.



Laboratory to ISOQA Technischer Dienst GmbH  
 Web: [www.isoqa.org](http://www.isoqa.org)  
 E-mail: [isoqa@isoqa.org](mailto:isoqa@isoqa.org)

**3. Performance test(s)****3.1. Photometric measurements test record - Passing Beam**

Type Name : HU303-00-1 Engineer : Bo Yang Lee  
 Function : Passing Beam Class : Class B  
 Flux : 13.2V: 1550 lm Light Source : 1 x H1  
 Test Distance : 25 m Current : 4.727 A / 4.727 A

Test Point	Angular Coordinates - Degrees	Minimum (cd)	Maximum (cd)	Sample 1 (LH) <sup>(1)</sup>		Sample 2 (RH) <sup>(1)</sup>	
				1 min	Stable	1 min	Stable
Point 50V	0.86D, 0	5,100	-	-	12,080.00	-	12,390.00
Point B50L	0.57U, 3.43L	-	350	-	199.00	-	98.60
Point BR	1.0U, 2.5R	-	1,750	-	205.70	-	102.70
Point 75R	0.57D, 1.15R	10,100	-	-	11,050.00	-	11,530.00
Point 75L	0.57D, 3.43L	-	10,600	-	2,953.00	-	4,269.00
Point 50L	0.86D, 3.43L	-	13,200	-	5,479.00	-	6,392.00
Point 50R	0.86D, 1.72R	10,100	-	-	11,390.00	-	11,310.00
Point 25L	1.72D, 9.0L	1,700	-	-	2,059.00	-	2,394.00
Point 25R	1.72D, 9.0R	1,700	-	-	1,928.00	-	2,320.00
Point 1	4U, 8L	-	625	-	56.90	-	74.00
Point 2	4U, 0	-	625	-	72.90	-	72.20
Point 3	4U, 8R	-	625	-	65.40	-	79.70
Point 4	2U, 4L	-	625	-	109.60	-	103.60
Point 5	2U, 0	-	625	-	138.90	-	142.00
Point 6	2U, 4R	-	625	-	129.70	-	131.20
Point 7	0, 8L	65	625	-	199.10	-	158.50
Point 8	0, 4L	125	625	-	310.40	-	236.70
Zone III	8L/1U - 8L/4U - 8R/4U - 8R/2U - 6R/1 5U - 1 5R/1.5U - V-VH-H - 4L/H-H	-	625	-	504.61	-	421.79
Zone IV	0.86D to 1.72D, 5.15L to 5.15R	2,500	-	-	3,880.00	-	4,680.00
Zone I	1.72D to 4D, 9L to 9R	-	2 x 50R	-	13,505.89	-	14,079.12
Point 1+2+3		190	-	-	195.20	-	225.90
Point 4+5+6		375	-	-	378.20	-	376.80

**- Illumination configuration for different traffic conditions <sup>(2)</sup>**

0.57U - 3.43R	-	880	-	456.90	-	578.70
0.86D - 1.72L	2,500	-	-	10,230.00	-	10,780.00
<b>Result</b>				-	PASS	PASS

<sup>(1)</sup> Value of 1 min not applicatable









## Test Report No. : ISOQA-14-0132-R112-HC

Approval No. : 112R-01 3922  
Type : HU303-00-1  
Manufacturer : JUN YAN AUTO INDUSTRIAL CO., LTD.



Laboratory to ISOQA Technischer Dienst GmbH  
Web: [www.isoqa.org](http://www.isoqa.org)  
E-mail: [isoqa@isoqa.org](mailto:isoqa@isoqa.org)

### 4. Communication

Concerning : APPROVAL GRANTED

of a type of device pursuant to Regulation No. 112

Approval No. 112R-01 3922 Extension No. 00

#### 4.1. Brief description

Category as described by the relevant marking : HC PL  
Number and category(s) of filament lamp(s): : 1 x H1  
Measures according to paragraph 5.8. of this Regulation : (b) Downward adjustment of the beam.

Number and specific identification code(s) of LED module(s) : N/A

Number and specific identification code(s) of electronic light source control gear(s) : N/A

Total objective luminous flux as described in paragraph 5.9. exceeds 2,000 lumen : NO

The adjustment of the cut-off has been determined at : 10m

The determination of the minimum sharpness of the "cut-off" has been carried out at : N/A

4.2. Approval mark position : on the lens

4.3. Reason(s) for extension (if applicable) : N/A

**Test Report No. : ISOQA-14-0132-R112-HC**

Approval No. : 112R-01 3922  
Type : HU303-00-1  
Manufacturer : JUN YAN AUTO INDUSTRIAL CO., LTD.



Laboratory to ISOQA Technischer Dienst GmbH  
Web: [www.isoqa.org](http://www.isoqa.org)  
E-mail: [isoqa@isoqa.org](mailto:isoqa@isoqa.org)

**5. Appendices**

- |                                    |                    |
|------------------------------------|--------------------|
| 1. Appendix 1 Information document | 1 page(s) in total |
| 2. Appendix 2 Drawing              | 2 page(s) in total |

**6. Statement of conformity**

The information folder respectively information document by the manufacturer and the type described therein are in compliance with the Test Specification mentioned above.

**ISOQA (Laboratory to ISOQA Technischer Dienst GmbH)**

Place : Taichung, Taiwan                      Date : 2015/2/2

Signature

A handwritten signature in black ink that reads 'Archer Chang'. The signature is written in a cursive, flowing style.

Laboratory Manager - Chih-Hua Chang

**JUN YAN AUTO INDUSTRIAL CO., LTD.**

No.121, Wencheng Road,  
704 Tainan, Taiwan, Republic of China

TEL: 886-6-2812396

FAX: 886-6-2812397

**INFORMATION**

for Initial Application

Date: 2014/3/17

Manufacturer's Name and Address	JUN YAN AUTO INDUSTRIAL CO., LTD. No.121, Wencheng Road, 704 Tainan, Taiwan, Republic of China	
Trade name or mark	JUNYAN	
Type Name	HU303-00-1	
Material of Lens(es)	Sabic Lexan LS-2 111 with UVHC 3000 Coating	
Rate Voltage	12V	
Rate Wattage	see below	
Front Direction Indicator ( R6.01 )	Category	1
	Light Source	1 x PY21W, 12V, 21W
	Color of light emitted	Amber
	Color of lens	Clear
Front Position Lamp ( R7.02 )	Category	A
	Light Source	39 x LED, 12V, 3W
	Color of light emitted	White
	Color of lens	Clear
Daytime running lamp ( R87.00 )	Category	RL
	Light Source	39 x LED, 12V, 18W
	Color of light emitted	White
	Color of lens	Clear
Passing Beam ( R112.01 )	Category	HC
	Class	Class B
	Light Source	1 x H1, 12V, 55W
	Color of light emitted	White
	Color of lens	Clear
Driving Beam ( R112.01 )	Category	HR
	Class	Class B
	Light Source	1 x H1, 12V, 55W
	Color of light emitted	White
	Color of lens	Clear

NO	SYM	DATE	REVISIONS	DWN.	CHECK	APPR.

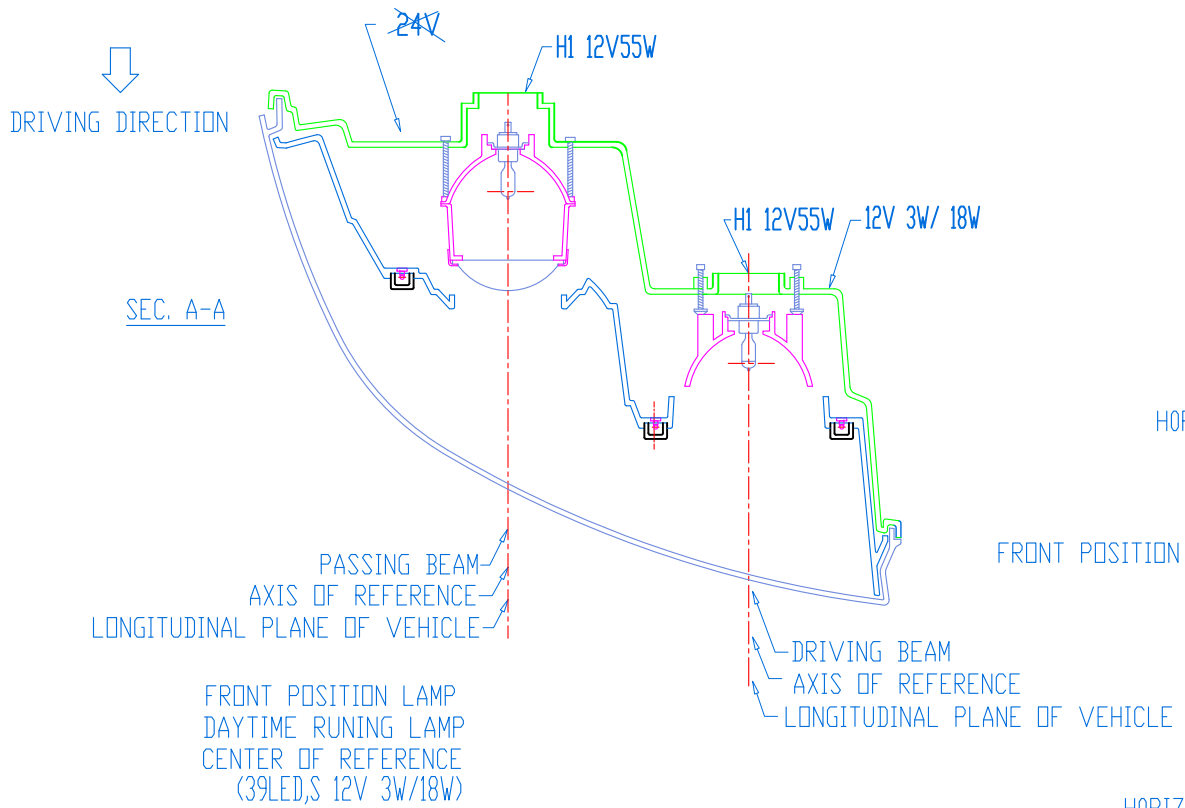

NOTE:1 THIS DRAWING SHALL BE APPLIED FOR RIGHT HAND ONLY, AND LEFT HAND SHALL BE SYMMETRIC.  
2. LENS IS FIXED WITH HOUSING BY GLUE AND CLIPS.

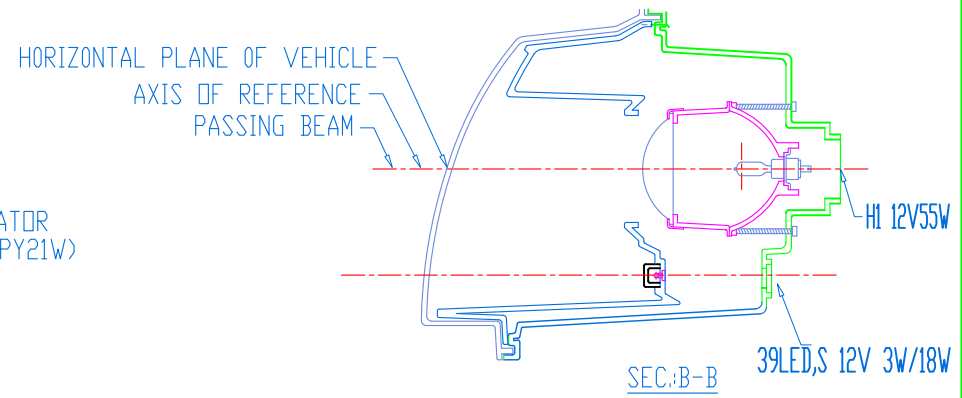
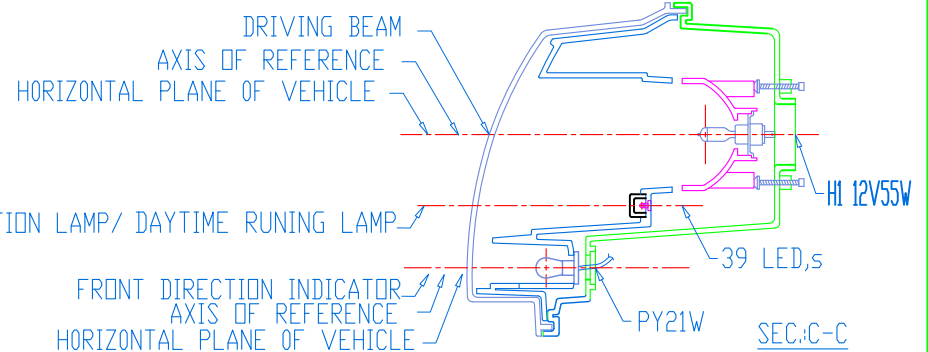
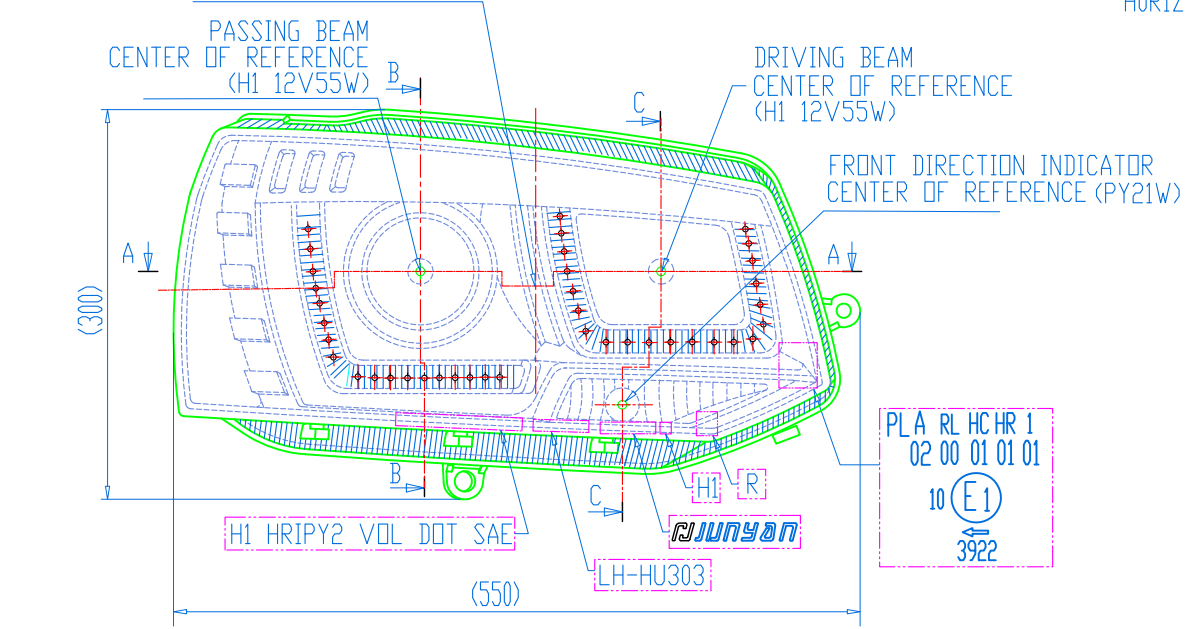

NO	FIG	NO.	CUSTOMER PART NO.	PART NO.	PART NAME	MATERIAL	QTY		REMARK
							R	L	
MARK OF INDICATION	REVISIONS	APPR.	CHECKED	SCL.	FREE	UNIT	mm	2014.12.30	
	GENERALLY-USED PARTS	DGN BY	DWG BY	DATE					
3rd ANGLE PROJECTION		PART NAME	HEAD LAMP			DRAW NO.	HU303-00-1(頭燈)		

JUNYAN AUTO INDUSTRIAL CO.,LTD.

# LDS-HU303

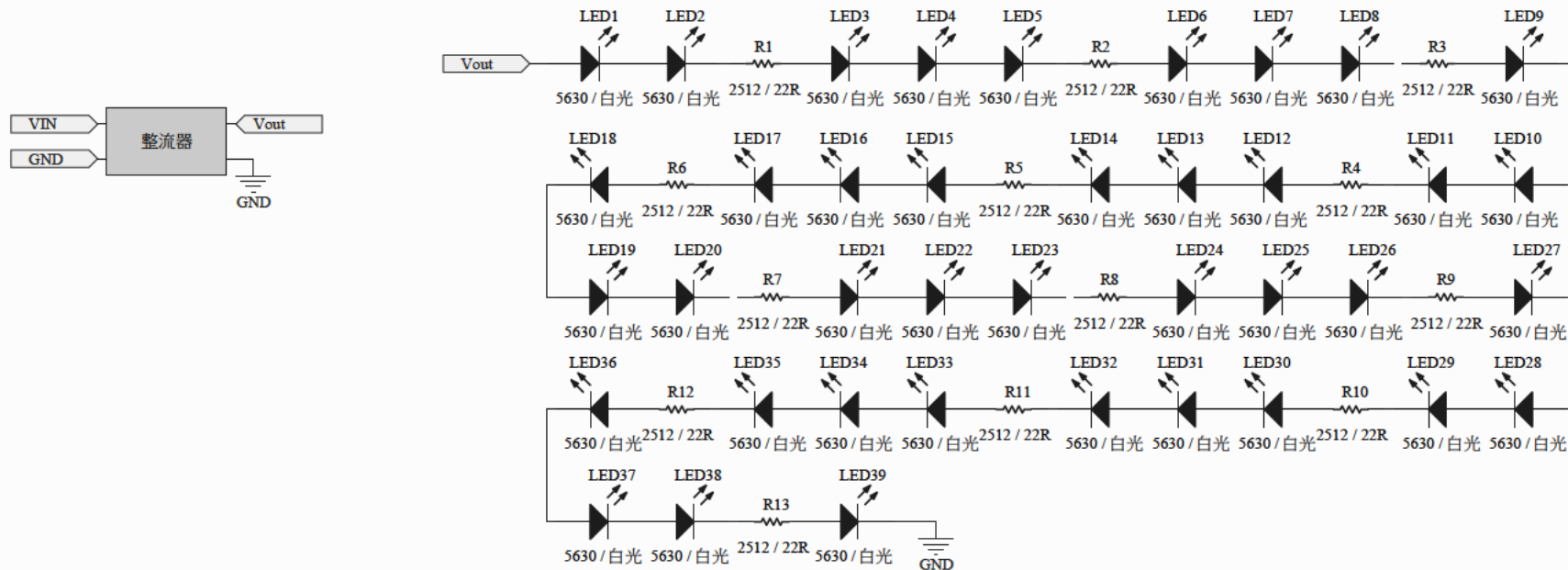

			Document Title: LDS-HU303		
			Document Number: PCB No.		
Sheet: Schematic Section			Revision: 00		
Size: A4		Draw By: ChiChin		Revision: 00	
Date: *		Time: *		Sheet 1 of 1	
File: Sheet1 SchDoc					



# Kraftfahrt-Bundesamt

DE-24932 Flensburg

---



## MITTEILUNG

ausgestellt von:

**Kraftfahrt-Bundesamt**

**über die Genehmigung**

für einen Scheinwerfertyp nach der Regelung Nr. 112  
**einschließlich der Änderung 01 Ergänzung 4**

## COMMUNICATION

issued by:

**Kraftfahrt-Bundesamt**

**concerning approval granted**

of a type of headlamp pursuant to Regulation No. 112  
**including amendment 01 supplement 4**

Nummer der Genehmigung: **013922**  
Approval No.:

Erweiterung Nr.: --  
Extension No.:

1. Fabrik- oder Handelsmarke der Einrichtung:  
Trade name or mark of the device:  
**JUNYAN**
2. Bezeichnung des Typs durch den Hersteller:  
Manufacturer's name for the type of device:  
**HU303-00-1**
3. Name und Anschrift des Herstellers:  
Manufacturer's name and address:  
**JUN YAN AUTO INDUSTRIAL CO., LTD.**  
**TW-Tainan City 704**
4. Gegebenenfalls Name und Anschrift des Vertreters des Herstellers:  
If applicable, name and address of manufacturer's representative:  
**Integrated Services of Quality Assessment**  
**TW-41257 Da-Li, Taichung**



# Kraftfahrt-Bundesamt

DE-24932 Flensburg

---

2

Nummer der Genehmigung: 013922

Approval No.:

5. Vorgelegt zur Genehmigung am:

Submitted for approval on:

**09.02.2015**

6. Technischer Dienst, der die Prüfungen für die Genehmigung durchführt:

Technical service responsible for conducting approval tests:

**ISOQA Technischer Dienst GmbH**

**DE-76137 Karlsruhe**

7. Datum des Gutachtens des Technischen Dienstes:

Date of report issued by that service:

**02.02.2015**

8. Nummer des Gutachtens des Technischen Dienstes:

Number of report issued by that service:

**ISOQA-14-0132-R112-HR**

9. Kurzbeschreibung:

Brief description:

Kategorie nach der entsprechenden Aufschrift: **HR PL**

Category as described by the relevant marking:

Anzahl und Kategorie(n) der Glühlampe(n): **1 x H1**

Number and category(s) of filament lamp(s):

Für das Abblendlicht verwendeter Bezugslichtstrom (lm): **entfällt**

Reference luminous flux used for the principal passing beam (lm): **not applicable**

Betrieb des Abblendlichts bei ungefähr (V): **entfällt**

Principal passing beam operated at approximately (V): **not applicable**

Maßnahmen entsprechend Punkt 5.8. dieser Regelung: **entfällt**

Measures according to paragraph 5.8. of this Regulation: **not applicable**

Anzahl und spezifische Kennzeichnungs-codes der LED-Module und für jedes LED-Modul eine Angabe, ob es auswechselbar ist oder nicht: **entfällt**

Number and specific identification code(s) of LED module(s) and for each LED module a statement whether it is replaceable or not: **not applicable**

Anzahl und spezifische Kennzeichnungs-codes des elektronischen Lichtquellen-Vorschaltgerätes:

Number and specific identification code(s) of electronic light source control gear(s):

**entfällt**

**not applicable**





# Kraftfahrt-Bundesamt

DE-24932 Flensburg

---

3

Nummer der Genehmigung: 013922

Approval No.:

Objektiver Gesamtlichtstrom, wie beschrieben im Punkt 5.9., überschreitet 2.000 Lumen:

Total objective luminous flux as described in paragraph 5.9. exceeds 2.000 lumen:

**entfällt**

**not applicable**

Die Justierung der "Hell-Dunkel-Grenze" ist festgestellt worden bei: **entfällt**

The adjustment of the "cut-off" has been determined at: **not applicable**

Die Ermittlung der minimalen Schärfe der "Hell-Dunkel-Grenze" ist durchgeführt worden bei:

The determination of the minimum sharpness of the "cut-off" has been carried out at:

**entfällt**

**not applicable**

10. Stelle, an der das Genehmigungszeichen angebracht ist:

Approval mark position:

**auf der Abschlusscheibe**

**on the lens**

11. Grund (Gründe) für die Erweiterung der Genehmigung:

Reason(s) for extension of approval:

**entfällt**

**not applicable**

12. Die Genehmigung wird **erteilt**

Approval **granted**



# Kraftfahrt-Bundesamt

DE-24932 Flensburg

---

4

Nummer der Genehmigung: 013922

Approval No.:

13. Ort: **DE-24932 Flensburg**  
Place:
14. Datum: **26.02.2015**  
Date:
15. Unterschrift: **Im Auftrag**  
Signature:

Stephan Marxsen



16. Ein Verzeichnis der Unterlagen, die bei der Behörde hinterlegt sind, die die Genehmigung erteilt hat, und die bei Bedarf angefordert werden können, ist dieser Mitteilung beigelegt.  
The list of documents deposited with the Administrative Service which has granted approval is annexed to this communication and may be obtained on request.

## **Nebenbestimmungen und Rechtsbehelfsbelehrung** **Collateral clauses and instruction on right to appeal**

- 1 Prüfbericht mit Anlagen**  
**Test report with enclosures**



# Kraftfahrt-Bundesamt

DE-24932 Flensburg

---

Nummer der Genehmigung: 013922

Approval No.:

**- Anlage -**

## **Nebenbestimmungen und Rechtsbehelfsbelehrung**

### **Nebenbestimmungen**

Jede Einrichtung, die dem genehmigten Typ entspricht, ist gemäß der angewendeten Vorschrift zu kennzeichnen.

Das Genehmigungszeichen lautet wie folgt:

**HR PL**

**01**

**E1** 10

**3922**

Die Einzelerzeugnisse der reihenweisen Fertigung müssen mit den Genehmigungsunterlagen genau übereinstimmen. Änderungen an den Einzelerzeugnissen sind nur mit ausdrücklicher Zustimmung des Kraftfahrt-Bundesamtes gestattet.

Änderungen der Firmenbezeichnung, der Anschrift und der Fertigungsstätten sowie eines bei der Erteilung der Genehmigung benannten Zustellungsbevollmächtigten oder bevollmächtigten Vertreters sind dem Kraftfahrt-Bundesamt unverzüglich mitzuteilen.

Verstöße gegen diese Bestimmungen können zum Widerruf der Genehmigung führen und können überdies strafrechtlich verfolgt werden.

Die Genehmigung erlischt, wenn sie zurückgegeben oder entzogen wird, oder der genehmigte Typ den Rechtsvorschriften nicht mehr entspricht. Der Widerruf kann ausgesprochen werden, wenn die für die Erteilung und den Bestand der Genehmigung geforderten Voraussetzungen nicht mehr bestehen, wenn der Genehmigungsinhaber gegen die mit der Genehmigung verbundenen Pflichten – auch soweit sie sich aus den zu dieser Genehmigung zugeordneten besonderen Auflagen ergeben - verstößt oder wenn sich herausstellt, dass der genehmigte Typ den Erfordernissen der Verkehrssicherheit oder des Umweltschutzes nicht entspricht.

Das Kraftfahrt-Bundesamt kann jederzeit die ordnungsgemäße Ausübung der durch diese Genehmigung verliehenen Befugnisse, insbesondere die genehmigungsgerechte Fertigung sowie die Maßnahmen zur Übereinstimmung der Produktion, nachprüfen. Es kann zu diesem Zweck Proben entnehmen oder entnehmen lassen. Dem Kraftfahrt-Bundesamt und/oder seinen Beauftragten ist ungehinderter Zutritt zu Produktions- und Lagerstätten zu gewähren.

Die mit der Erteilung der Genehmigung verliehenen Befugnisse sind nicht übertragbar. Schutzrechte Dritter werden durch diese Genehmigung nicht berührt.



# Kraftfahrt-Bundesamt

DE-24932 Flensburg

---

2

Nummer der Genehmigung: 013922

Approval No.:

## **Rechtsbehelfsbelehrung**

Gegen diese Genehmigung kann innerhalb eines Monats nach Bekanntgabe Widerspruch erhoben werden. Der Widerspruch ist beim **Kraftfahrt-Bundesamt, Fördestraße 16, DE-24944 Flensburg**, schriftlich oder zur Niederschrift einzulegen.



# Kraftfahrt-Bundesamt

DE-24932 Flensburg

---

3

Nummer der Genehmigung: 013922

Approval No.:

**- Attachment -**

## **Collateral clauses and instruction on right to appeal**

### **Collateral clauses**

All equipment which corresponds to the approved type is to be identified according to the applied regulation.

The approval identification is as follows: - see German version -

The individual production of serial fabrication must be in exact accordance with the approval documents. Changes in the individual production are only allowed with express consent of the Kraftfahrt-Bundesamt.

Changes in the name of the company, the address and the manufacturing plant as well as one of the parties given the authority to delivery or authorised representative named when the approval was granted is to be immediately disclosed to the Kraftfahrt-Bundesamt.

Breach of this regulation can lead to recall of the approval and moreover can be legally prosecuted.

The approval expires if it is returned or withdrawn or if the type approved no longer complies with the legal requirements. The revocation can be made if the demanded requirements for issuance and the continuance of the approval no longer exist, if the holder of the approval violates the duties involved in the approval, also to the extent that they result from the assigned conditions to this approval, or if it is determined that the approved type does not comply with the requirements of traffic safety or environmental protection.

The Kraftfahrt-Bundesamt may check the proper exercise of the conferred authority taken from this approval at any time. In particular this means the compliant production as well as the measures for conformity of production. For this purpose samples can be taken or have taken. The employees or the representatives of the Kraftfahrt-Bundesamt may get unhindered access to the production and storage facilities.

The conferred authority contained with issuance of this approval is not transferable. Trade mark rights of third parties are not affected with this approval.

### **Instruction on right to appeal**

This approval can be appealed within one month after notification. The appeal is to be filed in writing or as a transcript at the **Kraftfahrt-Bundesamt, Fördestraße 16, DE-24944 Flensburg.**

**Test Report No. : ISOQA-14-0132-R112-HR**

Approval No. : 112R-01 3922  
Type : HU303-00-1  
Manufacturer : JUN YAN AUTO INDUSTRIAL CO., LTD.



Laboratory to ISOQA Technischer Dienst GmbH  
Web: [www.isoqa.org](http://www.isoqa.org)  
E-mail: [isoqa@isoqa.org](mailto:isoqa@isoqa.org)

## TEST REPORT

Agreement concerning the adoption of uniform technical prescription for wheeled vehicles, equipment and parts which can be fitted and/or be used on wheeled vehicles and the conditions for reciprocal recognition of approvals granted on the basis of these prescriptions.

**Uniform provisions concerning the approval of motor vehicle headlamps emitting an asymmetrical ~~passing beam or driving beam or both~~ and equipped with filament lamps and / or LED Modules**

**Tested according ECE-R112, Supplement 4 to 01 series of 15 July 2013**

Kind of device: Headlamp for Right-hand traffic system Driving Beam, Class B

Approval status	
X	Application for granting of a type approval
	Application for an extension of type approval No.
	Reason for the extension:

**Test Report No. : ISOQA-14-0132-R112-HR**

Approval No. : 112R-01 3922  
Type : HU303-00-1  
Manufacturer : JUN YAN AUTO INDUSTRIAL CO., LTD.



Laboratory to ISOQA Technischer Dienst GmbH  
Web: [www.isoqa.org](http://www.isoqa.org)  
E-mail: [isoqa@isoqa.org](mailto:isoqa@isoqa.org)

**0. General**

- 0.1. Make (trade name of manufacturer) : JUNYAN
- 0.2. Type : HU303-00-1
- 0.3. Class of the connecting device : Class B
- 0.4. Manufacturer's name and address : JUN YAN AUTO INDUSTRIAL CO., LTD.  
No.121, Wencheng Road,  
704 Tainan,  
Taiwan, Republic of China
- 0.5. Test laboratory : ISOQA (Laboratory to ISOQA Technischer Dienst GmbH)  
60, Yong Long Road,  
41257 Da-Li, Taichung  
Taiwan

**Test Report No. : ISOQA-14-0132-R112-HR**

Approval No. : 112R-01 3922  
 Type : HU303-00-1  
 Manufacturer : JUN YAN AUTO INDUSTRIAL CO., LTD.



Laboratory to ISOQA Technischer Dienst GmbH  
 Web: [www.isoqa.org](http://www.isoqa.org)  
 E-mail: [isoqa@isoqa.org](mailto:isoqa@isoqa.org)

**1. Test object (s)**

## 1.1. Information :

Material of Lens	Sabic Lexan LS-2 111 with UVHC 3000 Coating	
Material of Housing	Plastic	
Material of Reflector	Plastic	
Rated Voltage	12V	
Driving Beam	Category	HR
	Traffic System	Right-hand traffic system
	Light Source	1 x H1, 12V, 55W
	Color of light emitted	White
	Color of lens	Clear
	Grouped with	Direction indicator, Front position lamp, Daytime running lamp and Passing Beam
	Combined with	--
	Incorporated with	--
	Reference Mark for Driving Beam	10

1.2. Location of Marking : see Appendix 2

## 1.3. Remark(s) :

1.3.1. There are no objections against the variants that may be described in the Information folder respectively the information document by the manufacturer because adversely effects are not expected.

The lamps are part of the same assembly of grouped, combined or reciprocally incorporated lamps. Each of these lamps satisfies the requirements of the relevant regulation.

1.3.2. tests of plastic material please see: LTIK Report No. PMT 060 and PMT 060 N1



**Test Report No. : ISOQA-14-0132-R112-HR**

Approval No. : 112R-01 3922  
 Type : HU303-00-1  
 Manufacturer : JUN YAN AUTO INDUSTRIAL CO., LTD.



Laboratory to ISOQA Technischer Dienst GmbH  
 Web: [www.isoqa.org](http://www.isoqa.org)  
 E-mail: [isoqa@isoqa.org](mailto:isoqa@isoqa.org)

**2. Test Specification**

2.1. Place of test : Laboratory of ISOQA in Taiwan

2.2. Date of test : 2014/9/18 ~ 2014/12/17

2.3. Date of receipt of test device(s) : 2014/9/18

**2.4. Test results :****2.4.1. Markings (according to paragraph 3 and 4 of ECE R112-01)**

a.	Trade name or mark	Complies	see Appendix 2
b.	Light sources	Complies	see Appendix 2
c.	Space reserved for the approval mark	Complies	see Appendix 2
d.	LED module(s)	Not Applicable	
e.	Marking for headlamp designed to meet the requirements of both traffic systems or left-hand traffic system only.	Not Applicable	
f.	A symbol consisting of the number 24 crossed out by an oblique cross (x)	Complies	see Appendix 2

**2.4.2. General Specifications (according to paragraph 5 of ECE R112-01)**

a.	Conformity the specifications	Complies	
b.	Design and construction for satisfactory operation	Complies	
c.	Light source	Complies	
d.	Setting of headlamp designed for both traffic systems	Not Applicable	
e.	Tests for stability of photometric performance of headlamps in operation	Complies	see 3.4
f.	Test for plastic lens	Complies	see 3.5
g.	Alternative driving and/or passing beam	Not Applicable	
h.	Illumination configuration for different traffic conditions	Not Applicable	-

**Test Report No. : ISOQA-14-0132-R112-HR**

Approval No. : 112R-01 3922  
Type : HU303-00-1  
Manufacturer : JUN YAN AUTO INDUSTRIAL CO., LTD.



Laboratory to ISOQA Technischer Dienst GmbH  
Web: [www.isoqa.org](http://www.isoqa.org)  
E-mail: [isoqa@isoqa.org](mailto:isoqa@isoqa.org)

- 2.4.3. Illumination (according to paragraph 6 of ECE R112-01)
- |    |                       |                |         |
|----|-----------------------|----------------|---------|
| a. | General Provision     | Complies       |         |
| b. | Passing Beam          | Not Applicable |         |
| c. | Driving beams         | Complies       | see 3.1 |
| d. | Adjustable reflectors | Complies       | see 3.2 |
| e. | Photo-receptor        | Complies       |         |
- 2.4.4. Colour (according to paragraph 7 of ECE R112-01)
- |  |  |          |         |
|--|--|----------|---------|
|  |  | Complies | see 3.3 |
|--|--|----------|---------|
- 2.4.5. LED Module (according to Annex10 of ECE R112-01)
- |    |                                     |                |  |
|----|-------------------------------------|----------------|--|
| a. | Ageing                              | Not Applicable |  |
| b. | colour rendering - Red content      | Not Applicable |  |
| c. | uv-radiation                        | Not Applicable |  |
| d. | temperature stability - Illuminance | Not Applicable |  |
| e. | temperature stability - Colour      | Not Applicable |  |
| f. | objective luminous flux             | Not Applicable |  |
- 2.5. Remark (s)



**Test Report No. : ISOQA-14-0132-R112-HR**

Approval No. : 112R-01 3922  
 Type : HU303-00-1  
 Manufacturer : JUN YAN AUTO INDUSTRIAL CO., LTD.



Laboratory to ISOQA Technischer Dienst GmbH  
 Web: [www.isoqa.org](http://www.isoqa.org)  
 E-mail: [isoqa@isoqa.org](mailto:isoqa@isoqa.org)

**3.2. Additional Tests for Adjustable Reflector**

Type Name : HU303-00-1 Engineer : Bo Yang Lee  
 Function : Driving Beam Class : Class B  
 Flux : 13.2V: 1550 lm Light Source : 1 x H1  
 Test Distance : 25 m Current : same as photometric test

Test Point	Minimum (cd)	maximum (cd)	Vertically +2°		Vertically -2°	
			Sample 1 (LH)	Sample 2 (RH)	Sample 1 (LH)	Sample 2 (RH)
I'm	40500	215000.00	40916.12	44148.29	40967.43	44923.03
H-V	0.8 x I <sub>max</sub>	-	40210.00	41520.00	39870.00	40800.00
Result			PASS	PASS	PASS	PASS

**3.3. Color of light emitted test record**

Type Name : HU303-00-1 Engineer : Bo Yang Lee  
 Function : Driving Beam Light Source : 1 x H1  
 Flux : 13.2V: 1550 lm Current : same as photometric test  
 Distance : 2.904 m Colour : White

Point	Sample 1 (LH) <sup>(1)</sup>				Sample 2 (RH) <sup>(1)</sup>			
	1 min		Value		1 min		Value	
	x	y	x	y	x	y	x	y
50V	-	-	0.4336	0.4074	-	-	0.4335	0.4073
50R	-	-	0.4324	0.4087	-	-	0.4332	0.4089
75R	-	-	0.4324	0.4089	-	-	0.4327	0.4084
Result	-		PASS		-		PASS	

<sup>(1)</sup> Value of 1 min not applicatable

**Test Report No. : ISOQA-14-0132-R112-HR**

Approval No. : 112R-01 3922  
 Type : HU303-00-1  
 Manufacturer : JUN YAN AUTO INDUSTRIAL CO., LTD.



Laboratory to ISOQA Technischer Dienst GmbH  
 Web: [www.isoqa.org](http://www.isoqa.org)  
 E-mail: [isoqa@isoqa.org](mailto:isoqa@isoqa.org)

### 3.4. Stability of Photometric Performance of Headlamps in Operation

Type Name : HU303-00-1 Engineer : Elton Li  
 Function : Driving Beam Class : Class B  
 Flux : 13.2V: 1550 lm Light Source : 1 x H1

#### - Test for Stability of Photometric Performance

Test Point	clean headlamp before burn in		clean headlamp after burn in		dirty headlamp after burn in	
	Value (cd)	dif. (%)	Value (cd)	dif. (%)	Value (cd)	dif. (%)
RHT						
I <sub>max</sub>	43404.56	-	41440.30	4.5%	39180.88	5.45%
Result	-		PASS		PASS	

For clean headlamp test the headlamps continuously operated for 12 hours; for dirty headlamp test the headlamps continuously operated for 1 hour.  
 After the test, there is no distortion, deformation, cracking or change in colour of either the headlamp lens or the external lens.

### 3.5. Tests on Complete Headlamps

#### 3.5.1. Mechanical deterioration

Type Name : HU303-00-1 Engineer : Elton Li  
 Function : Driving Beam Class : Class B  
 Flux : 13.2V: 1550 lm Light Source : 1 x H1

Test Point	Minimum (cd)	maximum (cd)	Value (cd)
H-V	29160	-	35789.4
Result			PASS

#### 3.5.2. Adherence of coatings

The impaired area: 1% ( does not exceed 15 per cent of the gridded surface. )

**Test Report No. : ISOQA-14-0132-R112-HR**

*Approval No.* : 112R-01 3922  
*Type* : HU303-00-1  
*Manufacturer* : JUN YAN AUTO INDUSTRIAL CO., LTD.



Laboratory to ISOQA Technischer Dienst GmbH  
Web: [www.isoqa.org](http://www.isoqa.org)  
E-mail: [isoqa@isoqa.org](mailto:isoqa@isoqa.org)

**Test Report No. : ISOQA-14-0132-R112-HR**

Approval No. : 112R-01 3922  
Type : HU303-00-1  
Manufacturer : JUN YAN AUTO INDUSTRIAL CO., LTD.



Laboratory to ISOQA Technischer Dienst GmbH  
Web: [www.isoqa.org](http://www.isoqa.org)  
E-mail: [isoqa@isoqa.org](mailto:isoqa@isoqa.org)

**4. Communication**

Concerning : APPROVAL GRANTED

of a type of device pursuant to Regulation No. 112

Approval No. 112R-01 3922                      Extension No. 00

4.1. Brief description

Category as described by the relevant marking : HR PL

Number and category(s) of filament lamp(s): : 1 x H1

Measures according to paragraph 5.8. of this Regulation : N/A

Number and specific identification code(s) of LED module(s) : N/A

Number and specific identification code(s) of electronic light source control gear(s) : N/A

Total objective luminous flux as described in paragraph 5.9. exceeds 2,000 lumen : N/A

The adjustment of the cut-off has been determined at : N/A

The determination of the minimum sharpness of the "cut-off" has been carried out at : N/A

4.2. Approval mark position : on the lens

4.3. Reason(s) for extension (if applicable) : N/A

**Test Report No. : ISOQA-14-0132-R112-HR**

Approval No. : 112R-01 3922  
Type : HU303-00-1  
Manufacturer : JUN YAN AUTO INDUSTRIAL CO., LTD.



Laboratory to ISOQA Technischer Dienst GmbH  
Web: [www.isoqa.org](http://www.isoqa.org)  
E-mail: [isoqa@isoqa.org](mailto:isoqa@isoqa.org)

**5. Appendices**

- |    |                                 |                    |
|----|---------------------------------|--------------------|
| 1. | Appendix 1 Information document | 1 page(s) in total |
| 2. | Appendix 2 Drawing              | 2 page(s) in total |

**6. Statement of conformity**

The information folder respectively information document by the manufacturer and the type described therein are in compliance with the Test Specification mentioned above.

**ISOQA (Laboratory to ISOQA Technischer Dienst GmbH)**

Place : Taichung, Taiwan      Date : 2015/2/2

Signature

A handwritten signature in black ink that reads 'Archer Chang'. The signature is written in a cursive, flowing style.

\_\_\_\_\_  
Laboratory Manager - Chih-Hua Chang



**JUN YAN AUTO INDUSTRIAL CO., LTD.**

No.121, Wencheng Road,  
704 Tainan, Taiwan, Republic of China

TEL: 886-6-2812396

FAX: 886-6-2812397

**INFORMATION**

for Initial Application

Date: 2014/3/17

Manufacturer's Name and Address	JUN YAN AUTO INDUSTRIAL CO., LTD. No.121, Wencheng Road, 704 Tainan, Taiwan, Republic of China	
Trade name or mark	JUNYAN	
Type Name	HU303-00-1	
Material of Lens(es)	Sabic Lexan LS-2 111 with UVHC 3000 Coating	
Rate Voltage	12V	
Rate Wattage	see below	
Front Direction Indicator ( R6.01 )	Category	1
	Light Source	1 x PY21W, 12V, 21W
	Color of light emitted	Amber
	Color of lens	Clear
Front Position Lamp ( R7.02 )	Category	A
	Light Source	39 x LED, 12V, 3W
	Color of light emitted	White
	Color of lens	Clear
Daytime running lamp ( R87.00 )	Category	RL
	Light Source	39 x LED, 12V, 18W
	Color of light emitted	White
	Color of lens	Clear
Passing Beam ( R112.01 )	Category	HC
	Class	Class B
	Light Source	1 x H1, 12V, 55W
	Color of light emitted	White
	Color of lens	Clear
Driving Beam ( R112.01 )	Category	HR
	Class	Class B
	Light Source	1 x H1, 12V, 55W
	Color of light emitted	White
	Color of lens	Clear

NO	SYM	DATE	REVISIONS	DWN.	CHECK	APPR.

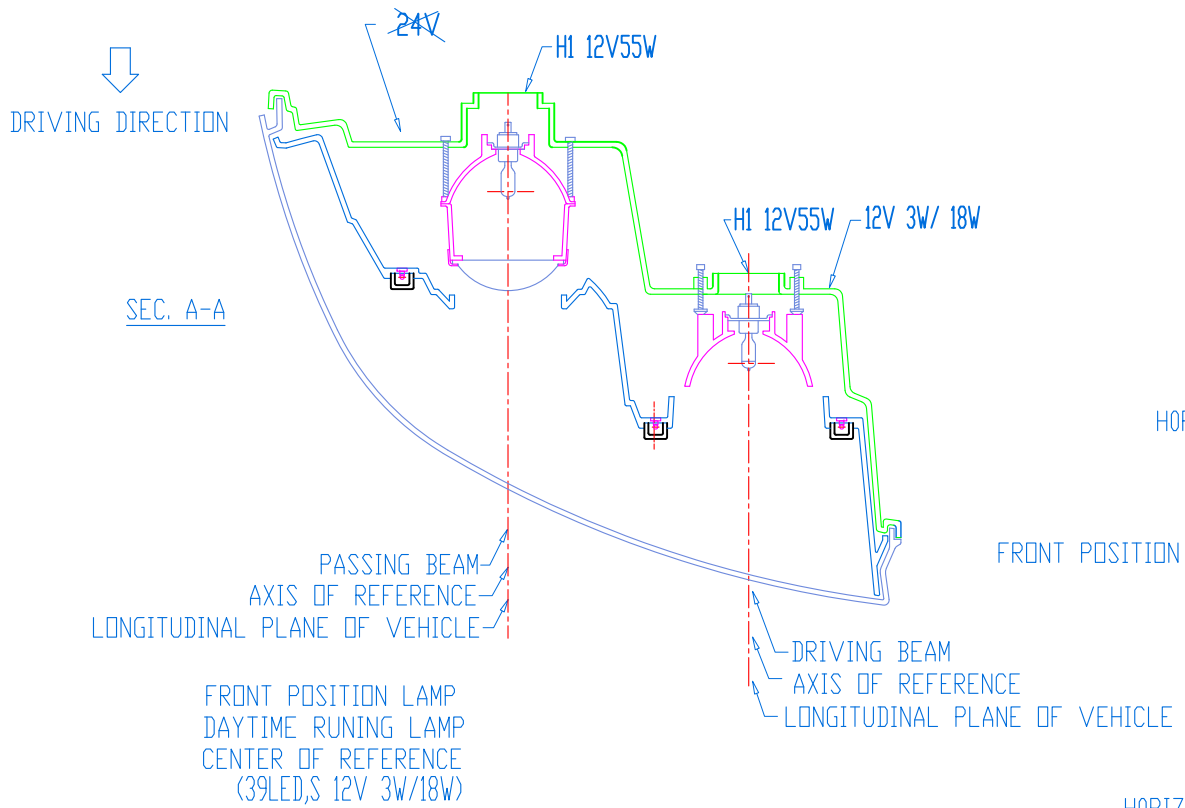

NOTE:1 THIS DRAWING SHALL BE APPLIED FOR RIGHT HAND ONLY, AND LEFT HAND SHALL BE SYMMETRIC.  
2. LENS IS FIXED WITH HOUSING BY GLUE AND CLIPS.

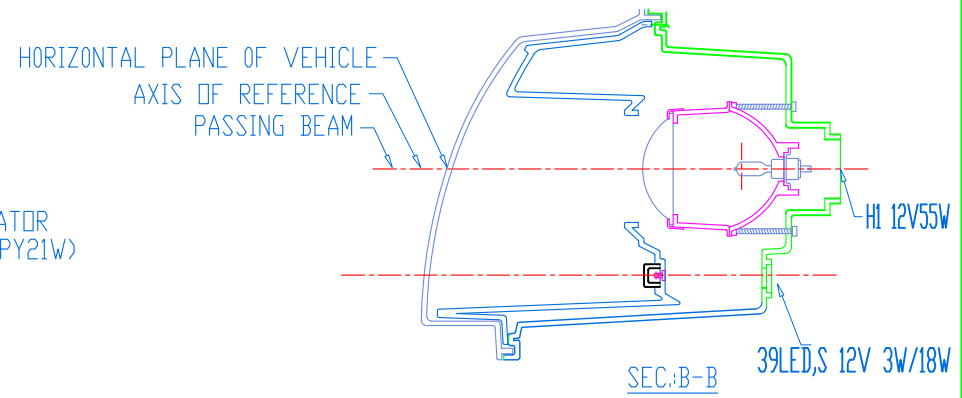
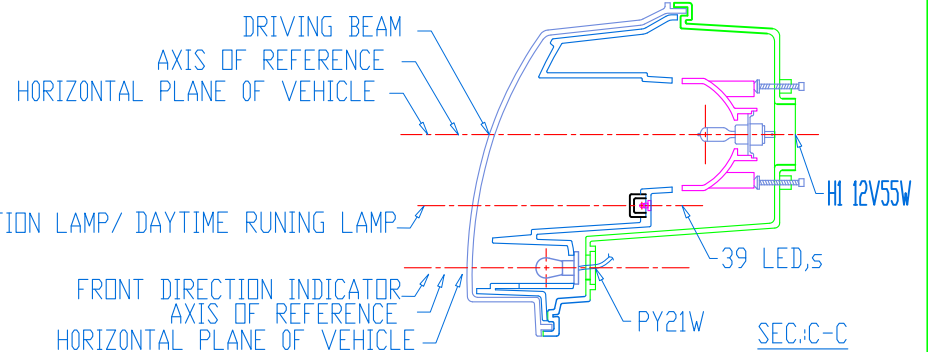
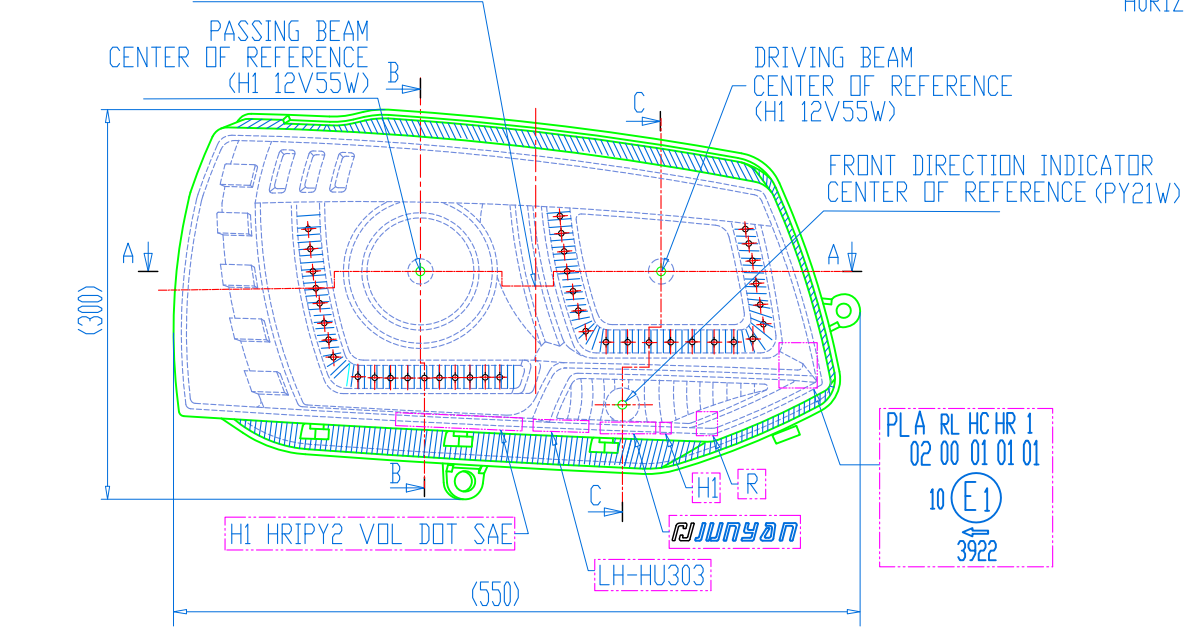

NO	FIG	NO.	CUSTOMER PART NO.	PART NO.	PART NAME	MATERIAL	QTY		REMARK
							R	L	
MARK OF INDICATION	REVISIONS	APPR.		CHECKED		SCL.	FREE	UNIT	mm
	GENERALLY-USED PARTS	DGN BY		DWG BY		DATE			2014.12.30
3rd ANGLE PROJECTION			PART NAME	HEAD LAMP			DRAW NO.	HU303-00-1(頭燈)	

JUNYAN AUTO INDUSTRIAL CO.,LTD.

# LDS-HU303

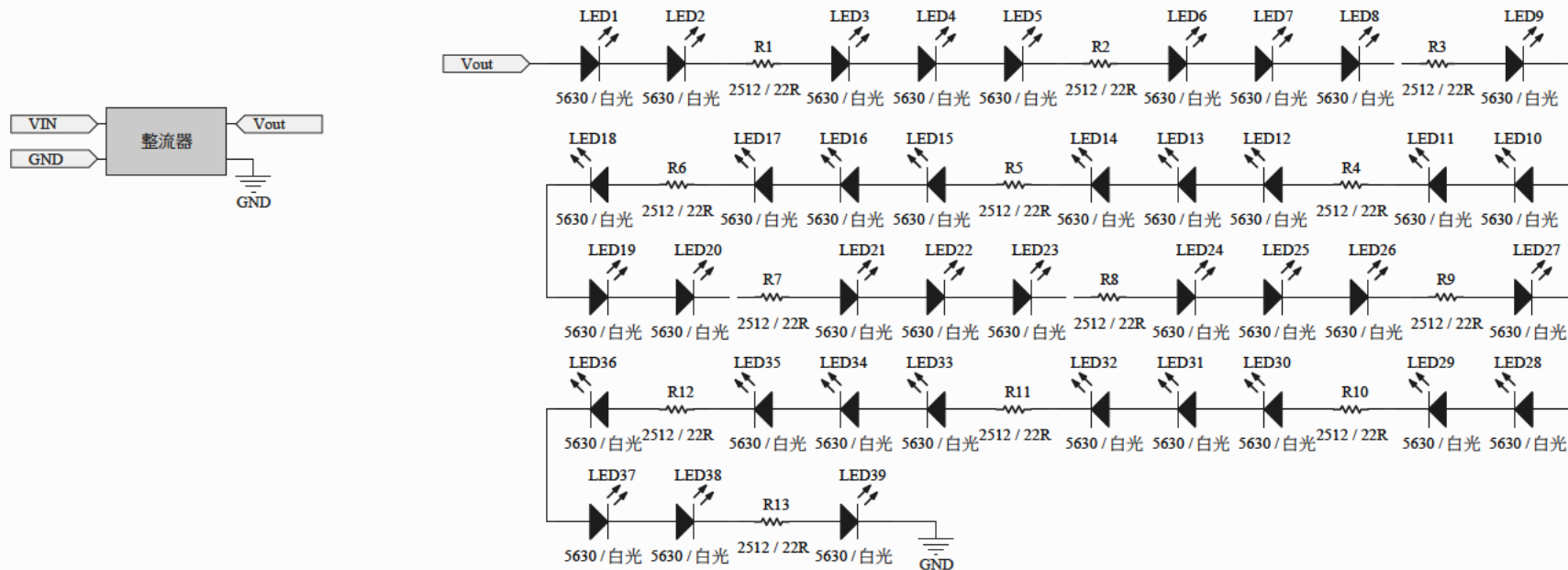

	Document Title: LDS-HU303		
	Document Number: PCB No.		
	Sheet: Schematic Section		
	Size: A4	Draw By: ChiChin	Revision: 00
	Date: *	Time: *	Sheet 1 of 1
File: Sheet1 SchDoc			