



**VCA Headquarters**  
1 The Eastgate Office Centre  
Eastgate Road  
Bristol, BS5 6XX  
United Kingdom

Switchboard: +44 (0) 117 951 5151  
Direct line: +44 (0) 117 952  
Main Fax: +44 (0) 117 952 4103  
Email: enquiries@vca.gov.uk  
Web: www.vca.gov.uk 4171

THE UNITED KINGDOM VEHICLE APPROVAL AUTHORITY

Rev 1/03



COMMUNICATION CONCERNING THE APPROVAL GRANTED OF A TYPE  
OF DIRECTION INDICATOR PURSUANT TO REGULATION NO 6.01

Approval No: 011497

1.

Trade name or mark of the device:



2.

Manufacturer's name for the type of device: SK3301 35103 and SK3302 K35103

3.

Manufacturer's name and address:

Sonar Auto Parts Company Limited  
No.427, Sec.2 Wenhua Road  
Panchiao  
Taipei  
Taiwan

4.

If applicable, name and address of the manufacturer's representative: Not applicable

5

Submitted for approval on: 27 February 2007

6.

Technical service responsible for conducting the approval tests: Vehicle Certification Agency

7.

Date of report issued by that service: 9 May 2007

8.

Number of report issued by that service: EAH177956



9. Concise description:  
Category: 1  
  
Number and category of filament lamp(s): 1 x PY21W  
  
Geometrical conditions of installation and relating variations, if any: Not applicable  
  
Only for limited mounting height of equal to or less than 750 mm above the ground: No

10. Position of the approval mark: On the lens

11. Reason(s) for extension (if applicable): Not applicable

12. Approval: GRANTED

13. Place: BRISTOL

14. Date: 18 MAY 2007

15. Signature: 

A.W.STENNING  
Head of Product Certification

16. The list of documents deposited with the Administrative Service which has granted approval is annexed to this communication and may be obtained on request.



EAH177956



VCA Headquarters  
1 The Eastgate Office Centre  
Eastgate Road  
Bristol, BS5 6XX  
United Kingdom

Switchboard: +44 (0) 117 951 5151  
Direct line: +44 (0) 117 952  
Main Fax: +44 (0) 117 952 4103  
Email: enquiries@vca.gov.uk  
Web: www.vca.gov.uk 417

THE UNITED KINGDOM VEHICLE APPROVAL AUTHORITY

Rev 1/03



COMMUNICATION CONCERNING THE APPROVAL GRANTED OF A TYPE  
OF DEVICE PURSUANT TO REGULATION NO: 7.02

Approval No: 021497

1. Trade name or mark of the device:



2. Manufacturer's name for the type of device: SK3301 35103 and SK3302 35103

3. Manufacturer's name and address:

Sonar Auto Parts Company Limited  
No.427, Sec.2 Wenhua Road  
Panchiao  
Taipei  
Taiwan

4. If applicable, name and address of the manufacturer's representative: Not applicable

5. Submitted for approval on: 27 February 2007

6. Technical service responsible for conducting the approval tests: Vehicle Certification Agency

7. Date of report issued by that service: 9 May 2007

8. Number of report issued by that service: EAH177956



9. Concise description:

By category of lamp: A

For mounting either outside or inside or both: Outside

Colour of light emitted: White

Number and category of filament lamp(s): 1 x W5W

Special supply voltage: 12 Volts

Application of additional supply system: No

Switched power supply: Not applicable

Geometrical conditions or installation and relating variations if any: Not applicable

Only for limited mounting height or equal to or less than 750mm above the ground: No

10. Position of the approval mark: On the lens

11. Reason(s) for extension (if applicable): Not applicable

12. Approval: GRANTED

13. Place: BRISTOL

14. Date: 18 MAY 2007

15. Signature: 

A.W. STENNING  
Head of Product Certification

16. The list of documents deposited with the Administrative Service which has granted approval is annexed to this communication and may be obtained on request.

EAH177956





**VCA Headquarters**  
1 The Eastgate Office Centre  
Eastgate Road  
Bristol, BS5 6XX  
United Kingdom

Switchboard: +44 (0) 117 951 5151  
Direct line: +44 (0) 117 952  
Main Fax: +44 (0) 117 952 4103  
Email: enquiries@vca.gov.uk  
Web: www.vca.gov.uk 4171

THE UNITED KINGDOM VEHICLE APPROVAL AUTHORITY

Rev 1/03



COMMUNICATION CONCERNING THE APPROVAL GRANTED OF A TYPE OF HEADLAMP PURSUANT TO REGULATION NO 112.00

Approval No: 001497

1.

Trade name or mark of the device:



2.

Manufacturer's name for the type of device: SK3301 35103 and SK3302 35103

3.

Manufacturer's name and address:

Sonar Auto Parts Company Limited  
No.427, Sec.2 Wenhua Road  
Panchiao  
Taipei  
Taiwan

4.

If applicable, name and address of the manufacturer's representative: Not applicable

5.

Submitted for approval on: 27 February 2007

6.

Technical service responsible for conducting the approval tests: Vehicle Certification Agency

7.

Date of report issued by that service: 9 May 2007

8.

Number of report issued by that service: EAH177956

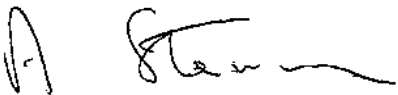

9. Concise description:  
Category as described by the relevant marking: HC/ for passing beam and  
HR for driving beam
- Number and category(ies) of filament lamp(s): 2 x H1 12V55W for passing beam and driving beam
10. Approval mark position: On the lens
11. Reason(s) for extension of approval: Not applicable
12. Approval : GRANTED
13. Place: BRISTOL
14. Date: 18 MAY 2007
15. Signature:  A.W. STENNING  
Head of Product Certification
16. The list of documents deposited with the Administrative Service which has granted approval is annexed to this communication and may be obtained on request.

EAH177956



# SONAR AUTO PARTS CO., LTD.

秀山交通器材股份有限公司

## Information Document

for Initial

application to ECE Homologation

of Model Number

SK3301 35103 and SK3302 35103

items	Details		Initial	Extension-00	Remark
1.	VCA				
1.1	Job Number		EAH177956		
1.2	Approval Number		1497		
2.	Manufacturer				
2.1	Name		SONAR AUTO PARTS CO., LTD.		
2.2	Address		No.427, SEC.2 WENHUA Rd., PANCHIAO, TAIPEI, TAIWAN		
2.3	Trade name or mark		SONAR		
3.	Product		Head lamp		
3.1	Model Number		SK3301 35103 and SK3302 35103		
3.2	Intended functions	Charteristic			
3.2.1	Front Direction Indicator (Reg. 6)	Category	1		
		Bulb	PY21W 12V 21W		
		Color of light	Amber		
		Color of lens	Clear		
3.2.2	Front Position Lamp (Reg.7)	Category	A		
		Bulb	W5W 12V 5W		
		Color of light	White		
		Color of lens	Clear		
3.2.3	Passing Beam (Reg.112)	Class	B		
		Category	HC/		
		Bulb	H1 12V 55W		
		Color of light	Clear		
		Color of lens	Clear		
3.2.4	Driving Beam (Reg.112)	Class	B		
		Category	HR		
		Bulb	H1 12V 55W		
		Color of light	Clear		
		Color of lens	Clear		
4.	Drawings		SK3301/02-35103		



NOTE: THIS DRAWING SHALL BE APPLIED FOR RIGHT HAND ONLY.

DRIVING DIRECTION  
  
 VEHICLE

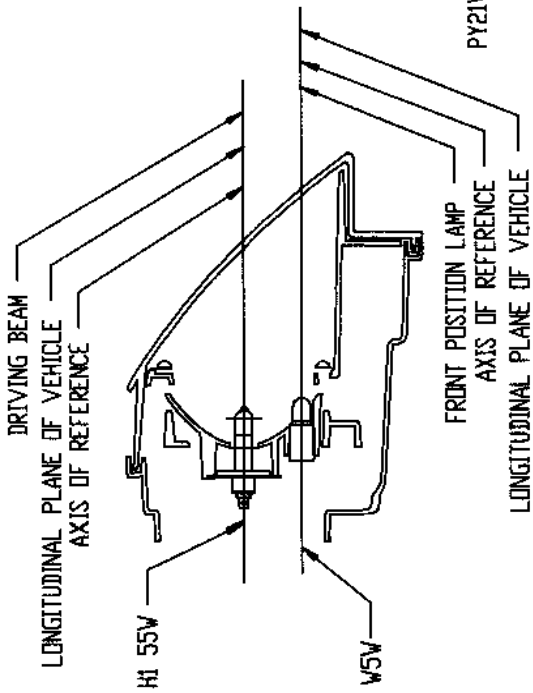

SEC-B-B

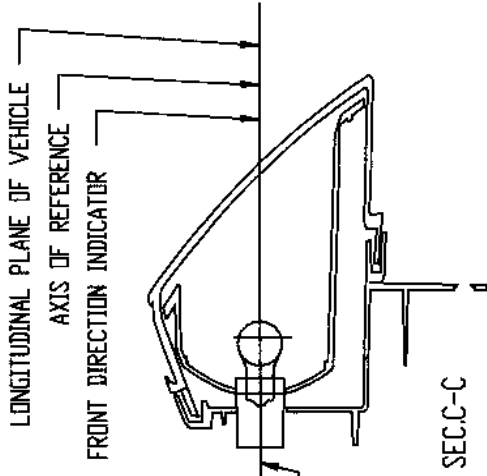

SEC-C-C

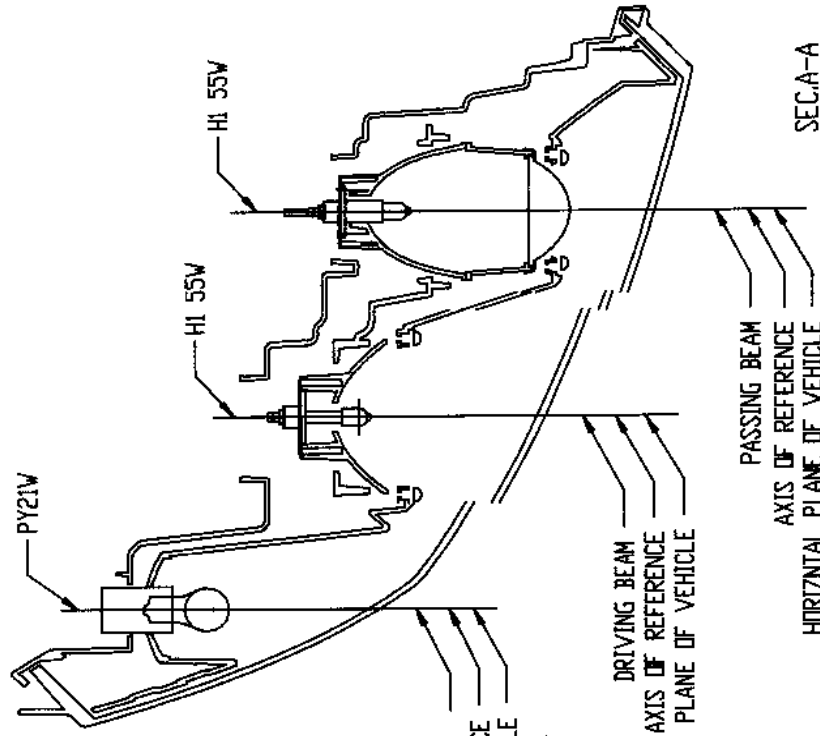

SEC-A-A

FRONT DIRECTION INDICATOR  
 AXIS OF REFERENCE  
 HORIZONTAL PLANE OF VEHICLE

DRIVING BEAM  
 AXIS OF REFERENCE  
 HORIZONTAL PLANE OF VEHICLE

PASSING BEAM  
 AXIS OF REFERENCE  
 HORIZONTAL PLANE OF VEHICLE

CENTER REFERENCE (H1 55W)

CENTER REFERENCE (H1 55W)

CENTER REFERENCE (W5W)

CENTER REFERENCE (PY21W)

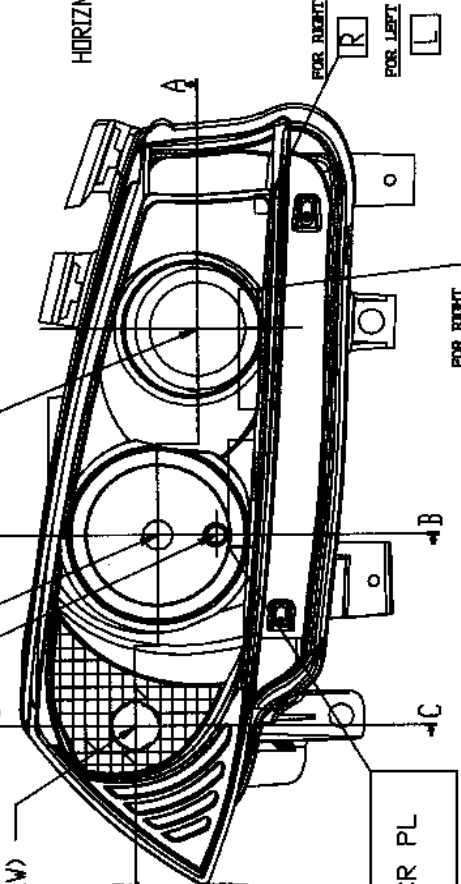

FOR RIGHT: E1101 1 02A 00 HCR PL 1497

FOR LEFT: E1101 1 02A 00 HCR PL 1497

FOR RIGHT: R  
 FOR LEFT: L  
 SONAR SK3301-35103

FOR LEFT: L  
 SONAR SK3302-35103

COMPANY	SONAR AUTO PARTS CO., LTD	
MODEL NAME	RH	SK3301-35103
	LH	SK3302-35103
FUNCTION	HEAD LAMP	